

# Installation manual

HKD 7

©2023

**BRUNNER**<sup>®</sup>  
*made in germany.*

---

# CONTENTS

<b>1</b>	<b>Basic informations.....</b>	<b>3</b>
<b>2</b>	<b>Overview HKD 7 / 8 / 9.....</b>	<b>4</b>
<b>3</b>	<b>Description of the stove/fireplace.....</b>	<b>5</b>
<b>4</b>	<b>Delivery contents.....</b>	<b>5</b>
<b>5</b>	<b>Description of parts.....</b>	<b>6</b>
5.1	HKD 7 Body.....	6
5.2	HKD 7 Front.....	7
5.3	HKD 7 Door.....	9
5.4	Inner linings for HKD 7 / 8 / 9.....	11
5.5	Mounting frame for HKD7.....	12
5.6	Door frame for HKD 7.....	13
5.7	Heating gas outlet.....	14
<b>6</b>	<b>Start of the installation of HKD 7.....</b>	<b>15</b>
6.1	Connection piece for the combustion air.....	17
6.2	Installation of the flue outlet.....	19
6.3	Installation of fireclay lining HKD 7 / 8 / 9.....	22
6.4	Installation fireclay lining HKD 7 / 8 / 9 double face.....	24
6.5	Installation of the deflector plates.....	27
6.6	Installation of the mounting frame.....	28
6.7	Installation of the door frame.....	30
<b>7</b>	<b>Combustion air setting.....</b>	<b>33</b>
<b>8</b>	<b>Setting of self-closing mechanism.....</b>	<b>36</b>
<b>9</b>	<b>Conversion of the door hinge.....</b>	<b>37</b>
<b>10</b>	<b>Drawings and technical data.....</b>	<b>43</b>

# 1 BASIC INFORMATIONS



All instructions delivered with products must be observed. We do not accept any warranty claim or liability for damage resulting from failure to observe these installation instructions!  
Improper installation can cause injury and material damage!

The installation may only be carried out by a registered specialist.

Fireplaces equipped with a water boiler must be pressure-tested after hydraulic connection to the heating system. Masonry work may follow only after this pressure test. Ulrich Brunner GmbH does not cover any costs incurred by necessary dismantling of masonry for rework at water boiler installation or replacement of the boiler.

The floor space of the room must have a suitable structure and sufficient dimensions to ensure proper functioning of the fireplace.

Please note that other installation and assembly instructions are included in other packaging units!

Dimensioning of downstream heat accumulator must be according to valid stove-setting rules.

During installation of the fireplace, all dimensions and minimal clearances of the fireplace casing must be held as specified by the manufacturer.

Fireplaces that meet the requirements of DIN EN 13240 or DIN EN 13229 and that can only be operated as intended with closed combustion chamber door or that have a self-closing firebox door are suitable for multiple occupancy.

All binding national or EU standards and local regulations for the installation of fireplaces must be observed.

All valid stove fitting rules and regulations of local construction law must be observed and followed.

Please follow the relevant regulations of your country.

When these instructions are followed and all works are done properly, this will ensure a safe, energy-saving and environmentally friendly operation of the stove. Pictures shown are not to be considered as complete representations of any kind.

Subject to technical and assortment changes.

Please notify your supplier of any damage which might have occurred during transport.

Please keep these instructions.

Please also take note of the online product documentation provided by:







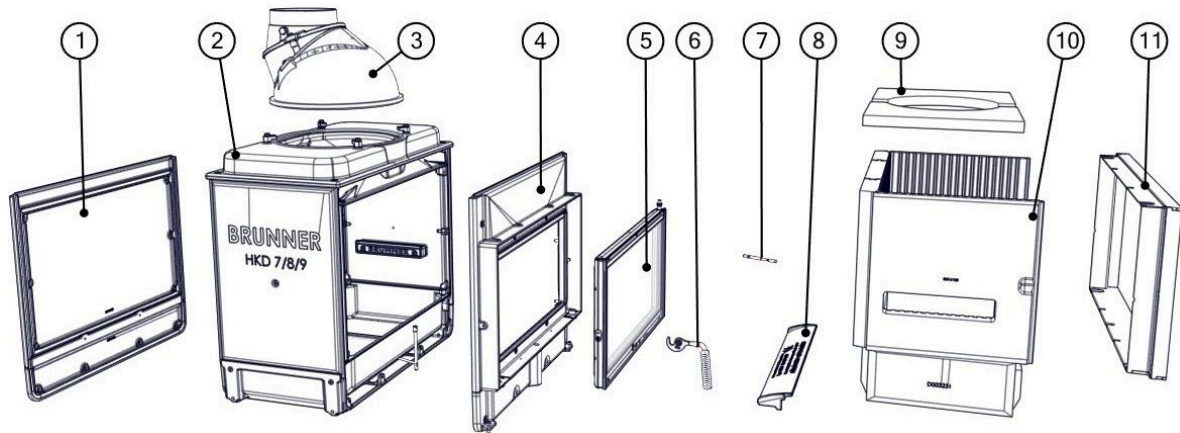

[\*\*General instructions of the Brunner products installation for the stove construction.\*\*](#)

([https://www.brunner.de/produktdownloads/kacheloefen-kamine/allgemeine-hinweise-fuer-den-aufbau\\_de.pdf](https://www.brunner.de/produktdownloads/kacheloefen-kamine/allgemeine-hinweise-fuer-den-aufbau_de.pdf)) laden können.



## 2 OVERVIEW HKD 7 / 8 / 9



Pos.	Description / Options	HKD 7	HKD 7 Tunnel	HKD 8	HKD 8 Tunnel	HKD 9	HKD 9 Tunnel
<b>Korpus:</b>							
1	Rear wall	✓	-	✓	-	✓	-
2	Korpus HKD	✓	✓	✓	✓	✓	✓
<b>Flue gas connection:</b>							
3	Cast iron dome Ø 200mm		○	○	○	○	○
	Cast iron dome Ø 180mm		○	○	○	○	○
	Cast iron dome Ø 200 mm low		○	○	○	○	○
	Accumulator MAS 440		○	○	○	○	○
<b>Front and door</b>							
4	Front HKD 7		✓	✓	-	-	-
	Front HKD 8		-	-	✓	✓	-
	Front HKD 9		-	-	-	-	✓
5	Side opening door with simple gass		○	○	○	○	○
	Side opening door with double gass		○	○	○	○	○
6	Door handle	✓	✓	✓	✓	✓	✓
7	Handle for combustion air control	✓ <sup>1)</sup>	✓ <sup>1)</sup>	✓ <sup>1)</sup>	✓ <sup>1)</sup>	✓ <sup>1)</sup>	✓ <sup>1)</sup>
8	Textplate	✓	✓	✓	✓	✓	✓
9	Deflector plates	✓	✓	✓	✓	✓	✓

Pos.	Description / Options	HKD 7	HKD 7 Tunnel	HKD 8	HKD 8 Tunnel	HKD 9	HKD 9 Tunnel
10	Fireclay lining set	✓	✓	✓	✓	✓	✓
11	Mountig frame	o	o	-	-	-	-
	Door frame	o	o	o	o	-	-

✓ = required      o = optional      - = not deliverable      1) = only for manual handling

### 3 DESCRIPTION OF THE STOVE/FIREPLACE

The fireplace has been approved according to EN 13229 and can be combined with a metallic radiator or ceramic accumulator for greater efficiency and heating power. It can be fitted with the optional electronic stove control system (EAS/EOS) at delivery or after the fireplace installation has been completed.

Combustion air can be supplied from outside by connecting to a separate air duct.

Combustion air is supplied through a provided connecting piece. The volume of air supplied for combustion can be controlled by using a combustion air regulator.

The HKD series are designed for closed installation without any vents (hypocaust principle). Design of a hypocaust must ensure uninterrupted transfer and even distribution of heat inside the casing, preventing all parts of the heating chamber from overheating. Dimensioning of heat projecting walls of the casing must be adjusted to performance data of the heating device. Thickness of insulation for building walls surrounding the fireplace stated in technical data has been determined during continuous operation with open air vents (safety test according to EN 13229 - heat transfer coefficient of the tested wall at 0,7 W/m<sup>2</sup>K), and must be amended accordingly for different conditions (for example, by providing air ventilation for walls).

When installing electric or electronic parts (controllers, sensors, cables...) or water-conducting parts, please consider the max. permitted surrounding temperatures for these components.

You can optionally upgrade the device with an electronic control system (EAS/EOS).

The HKD offers the possibility that the door hinge can be changed at any time, also if it is already built in.

### 4 DELIVERY CONTENTS

The delivery consists of different packaging units depending on the configuration of the system.

## 5 DESCRIPTION OF PARTS

### 5.1 HKD 7 BODY

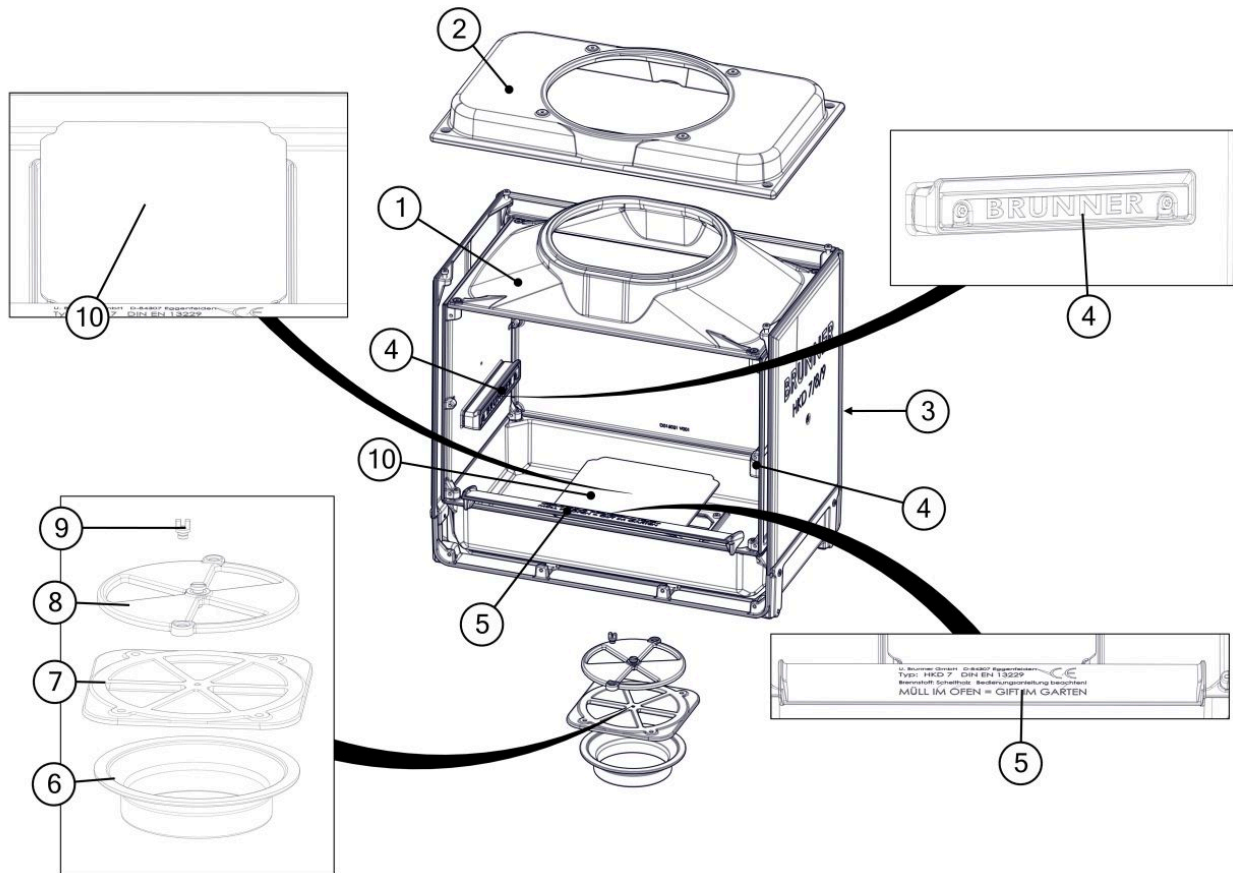

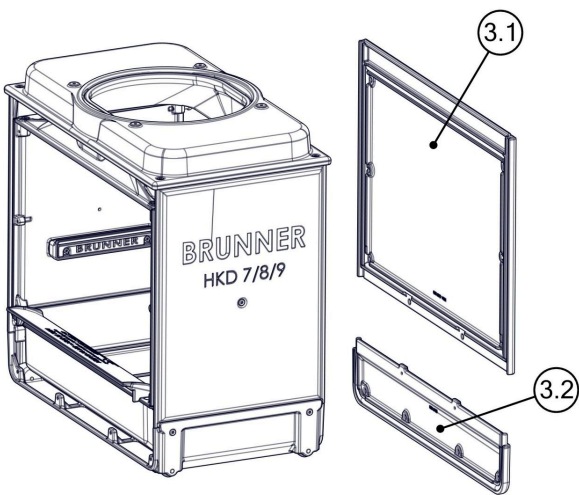

Item	Part No.	Designation	Pcs.
1	D016090	Inner cover assembly	1
2	D016016	Cover assembly with dome connection	1
3	D016012	Back wall assembly	1
3.1	D016107	Upper back wall assembly	1
3.2	D016106	Back wall lower part assembly	1
4	C010058	Air intake assembly	2
5	D016032	Text plate	1
6	D016087	Combustion air connection diam. 160	1
6	D016117	Optional: Combustion air connection diam. 125	1
7	D016116	Air intake plate	1
8	D003221	Turntable for combustion air	1
9	D003239	Air adjuster mounting	1
10	D016019	Revision cover assembly	1

## 5.2 HKD 7 FRONT

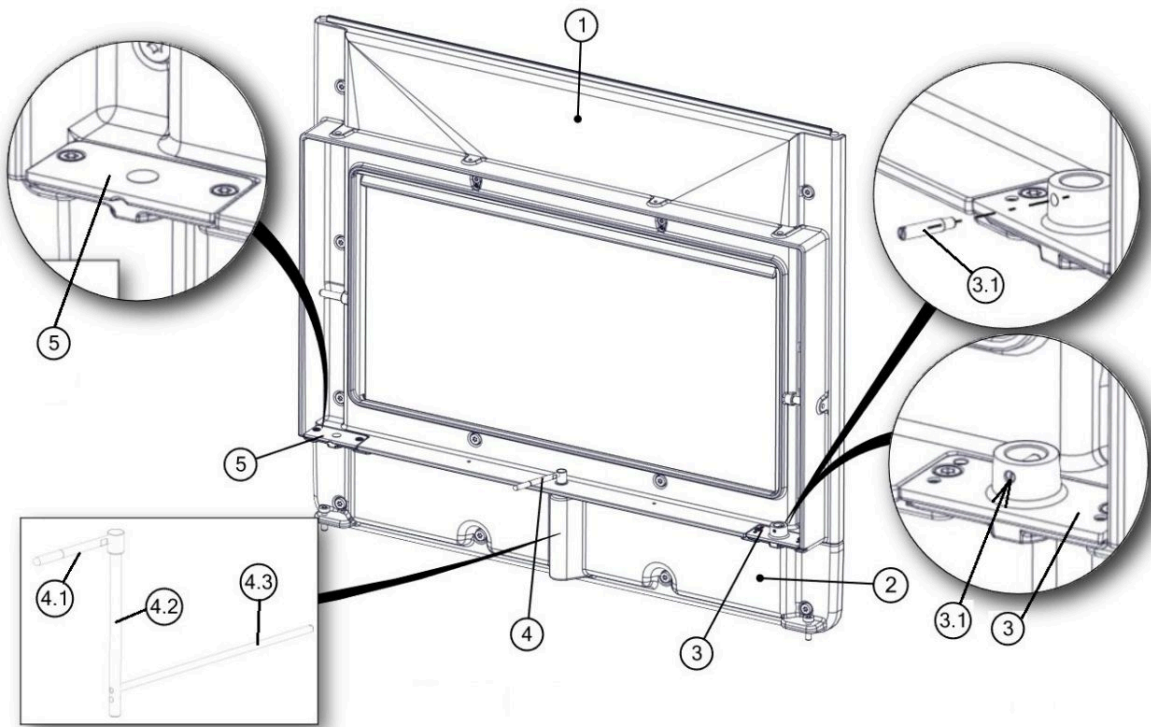

Item	Part No.	Designation	Pcs.
1	D016094	Front assembly	1

<b>Item</b>	<b>Part No.</b>	<b>Designation</b>	<b>Pcs.</b>
2	D016105	Front lower part assembly	1
3*	D016118	Hinge insert	1
4	D003238	Air adjustment lever assembly	1
4.1	D003484	Round air adjustment lever assembly	1
4.2	D003236	Air adjustment rod	1
4.3	D003237	Air adjustment actuator	1
5*	D003488	Door switch insert	1

\*Left-hand door: positioning of parts 3 and 5 is reversed.



### 5.3 HKD 7 DOOR

#### Single-glazed HKD 7 Door - Assembly D016006-01

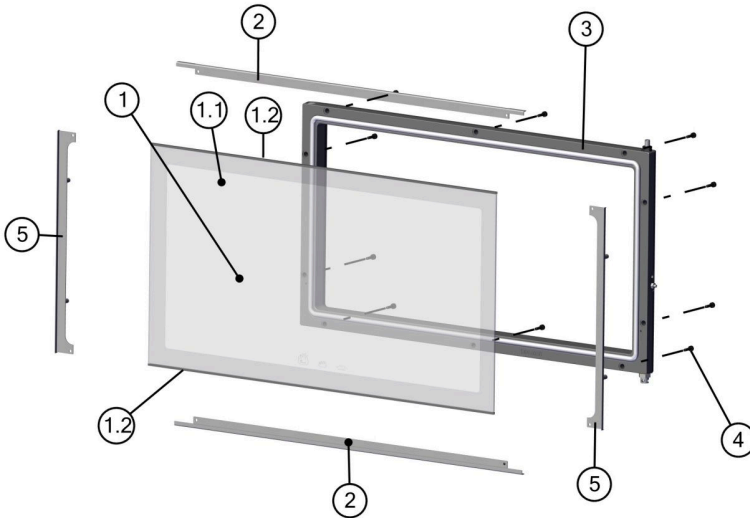

Item	Part No.	Designation	Pcs.
1	D016121-01	Single glass assembly	1
1.1	D016043-01	HKD 7 single glass with black border print	1
1.2	D016061	Glass sealing ribbon 10x0.2x650	2
2	D016040-01	SG top-bottom mounting frame assembly	2
3	D016005	Flat door frame assembly for single glass	1
4	02095	Cylinder screw TORX M5x16	10
6	D016004-01	SG left-right mounting frame assembly	2

#### Detail: Door frame

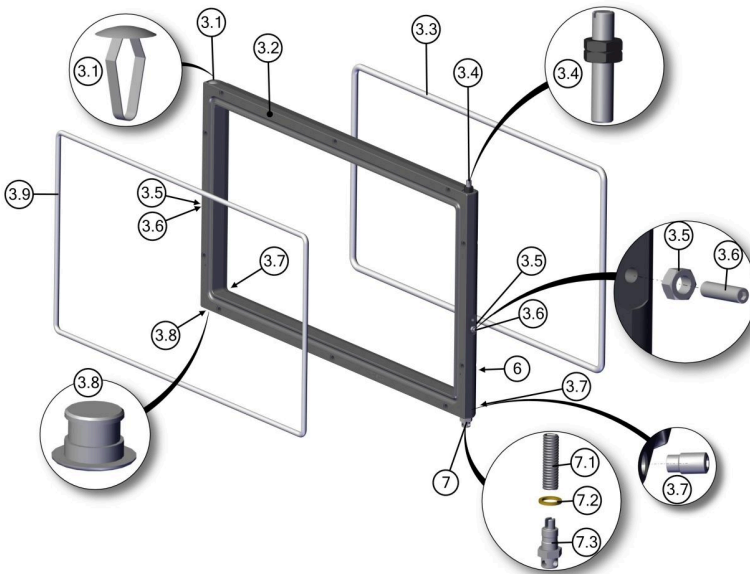

Item	Part No.	Designation	Pcs.
3	D016005	Flat door frame assembly for single glass	1
3.1	02079	Cover clamps for HKD	1
3.2	D016038	Flat door frame for single glass	1
3.3	D016059	Sealing rope for HKD 7 door D10x1860	1
3.4	D016093	Upper hinge bolt assembly	1
3.5	800216	Hexagon nut M5	2
3.6	800071	Threaded pin M5x12 DIN 913	2
3.7	00734	Threaded pin M5x8 DIN 915	2
3.8	D016122	Locking plug	1
3.9	D016060	Sealing rope for SG side-opening door D8x1850	1
6	800538	Grooved pin D3x24 DIN EN ISO 8745-3x24	1
7	D016133	Self-closing door hinge assembly	1
7.1	I013955	Closing spring	1
7.2	900426	Fit ring 13x18x2	1
7.3	D016132	Spring tensioner	1

**Double-glazed HKD 7 Door - Assembly D016010-01**

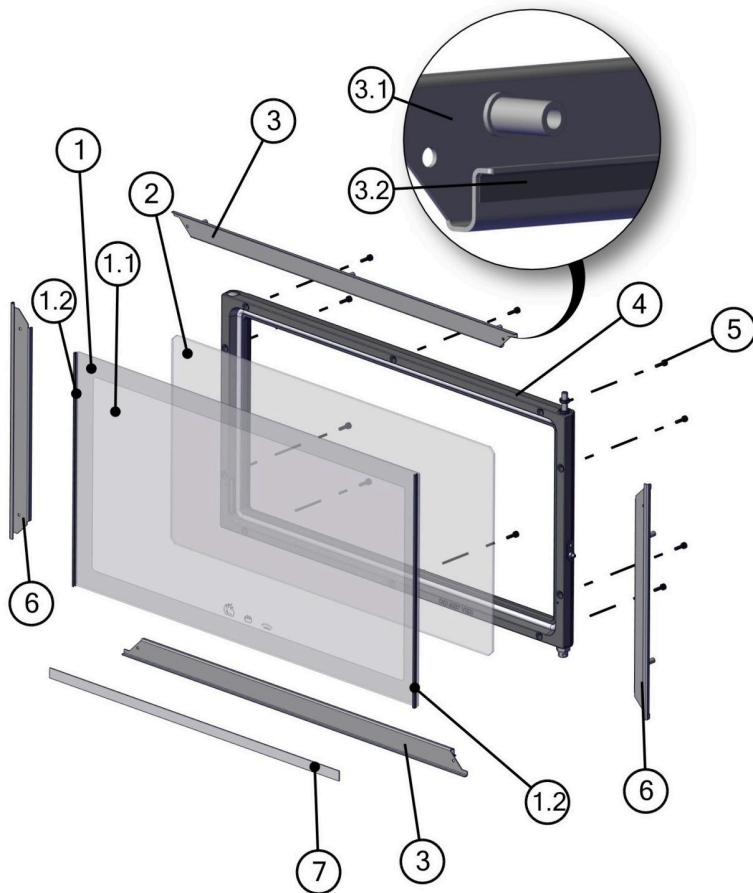

Item	Part No.	Designation	Pcs.
1	D016127	DG outer glass assembly	1
1.1	D016043-01	Washer	1
1.2	D016130	Glass sealing ribbon 10x0.2x350	2
2	D016034	HKD 7 inner glass	1
3	D016128	Glass mounting frame assembly for inner glass with seal	2
3.1	D016009-01	Glass mounting frame assembly for inner glass, black	2
3.2	D016129	Sealing ribbon for glass mounting frame 10x0.2x586	2
4	D016007	Flat door frame assembly for double glass	1
5	02095	Cylinder screws TORX M5x16	10
6	DIN1472 3x24	Grooved pin	1
7	D016077	Sealing ribbon for double glass bottom 15x1.2x550	1

Detail: Door frame

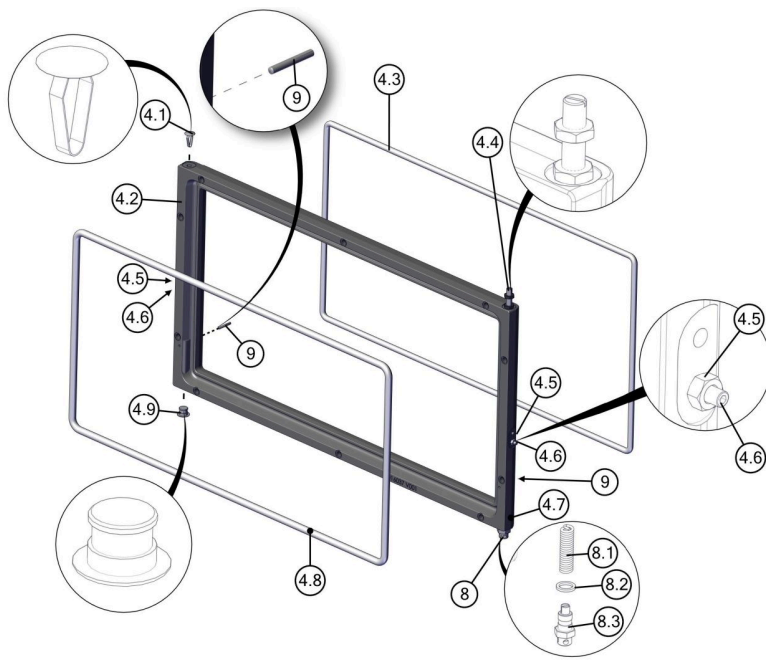

Item	Part No.	Designation	Pcs.
4	D016007	Flat door frame assembly for double glass	1
4.1	02079	Cover clamps for 8 mm hole	1
4.2	D016037	Flat door frame for double glass	1
4.3	D016059	Sealing rope for double-glazed HKD 7 door	1
4.4	D016093	Upper hinge bolt assembly	1
4.5	800216	Hexagon nut M5	2
4.6	800212	Threaded pin DIN 913 M5x16	2
4.7	00734	Threaded pin DIN 915 M5x8	2
4.8	D016058	Sealing rope for double-glazed HKD 7 door D8x1830	1
4.9	D016122	Locking plug	1
8	D016133	Self-closing door hinge assembly	1
8.1	I013955	Closing spring	1
8.2	900426	Fit ring 13x18x2	1
8.3	D016132	Spring tensioner	1
9	800538	Groove pin DIN1472 D3x24	2

## 5.4 INNER LININGS FOR HKD 7 / 8 / 9

### Assembly D016050

Item	PartNo.	No.	Designation
1	D016108	1	Left side wall stone
2	D016109	2	Rear wall external part
3	D016047	1	Rear wall inner part
4	D016046	1	Right side wall stone
5	20000	2	Ceramic fibre sealing 650x60x25
6	D003231	2	Side wedge
7	D016045	2	Bottom plate
8	D016049	2	Front wedge
9	D003232	1	Bottom plate
10	D016044	2	Rear wedge

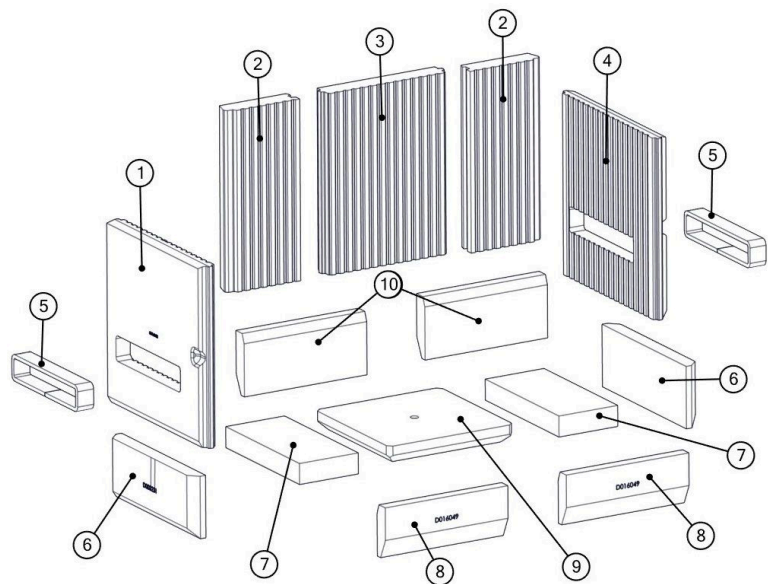

Im. 1: Inner linings for HKD 7 / 8 / 9

**HKD 7 / 8 / 9 Tunnel Assembly D016062**

Item	PartNo.	No.	Designation
1	D016063	4	Side wall upper part
2	D016123	2	Side wall lower part 1
3	D016049	4	Front wedge
4	D016124	2	Side wall lower part 2
5	D003231	2	Side wedge
6	D016045	2	HKD 7 bottom plate
7	D003232	1	HKD 2.2 bottom plate

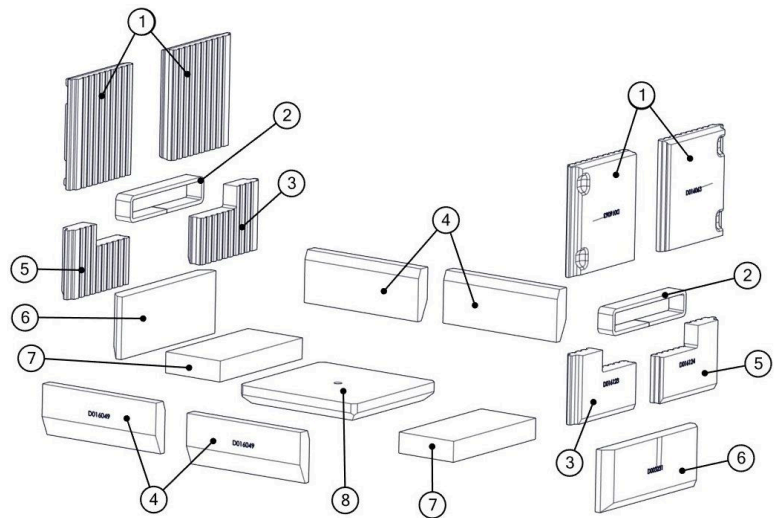

*Im. 2: Inner linings for HKD 7 / 8 / 9 Tunnel*

**5.5 MOUNTING FRAME FOR HKD7**

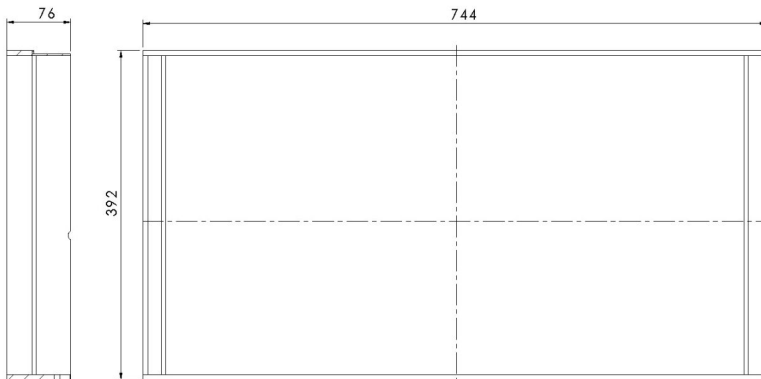

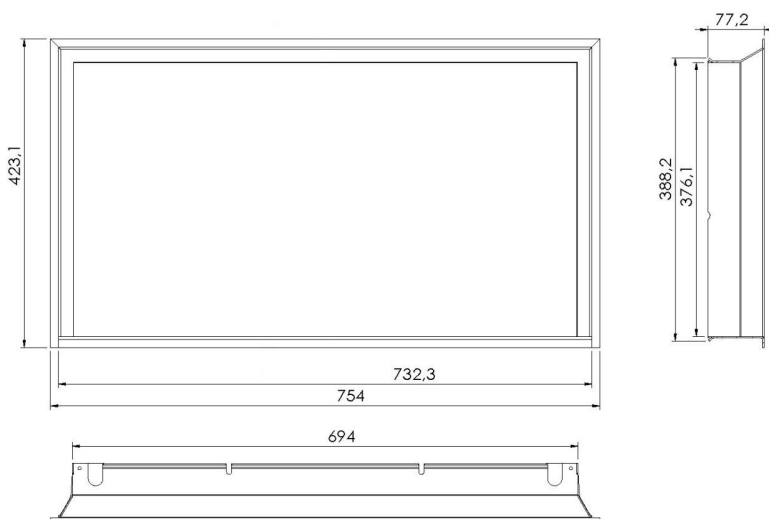

Art.No.	Description	Pcs.
D016070	Mounting frame HKD 7	1
01998	Accessories: screws	1

## 5.6 DOOR FRAME FOR HKD 7

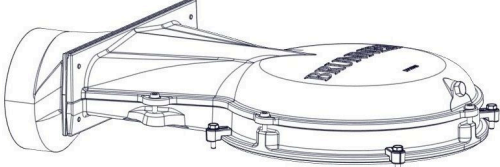
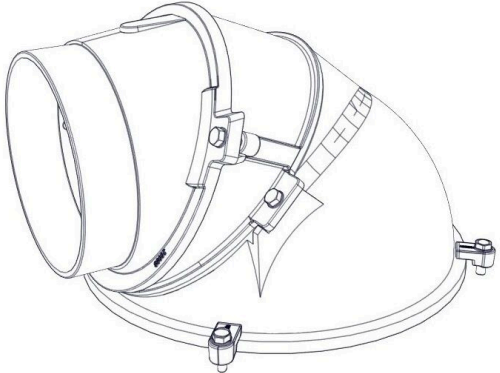

ArtNo.	Description	Pcs.
D016065	Door frame HKD 7	1
01998	Accessories screws	1

## 5.7 HEATING GAS OUTLET

Variants	PartNo.	
Low hood	D016139	
Cast iron hood Ø200	D004181	
Cast iron hood Ø 180	D004186	
Mounting ring MAS 440	10077	

## 6 START OF THE INSTALLATION OF HKD 7

1:

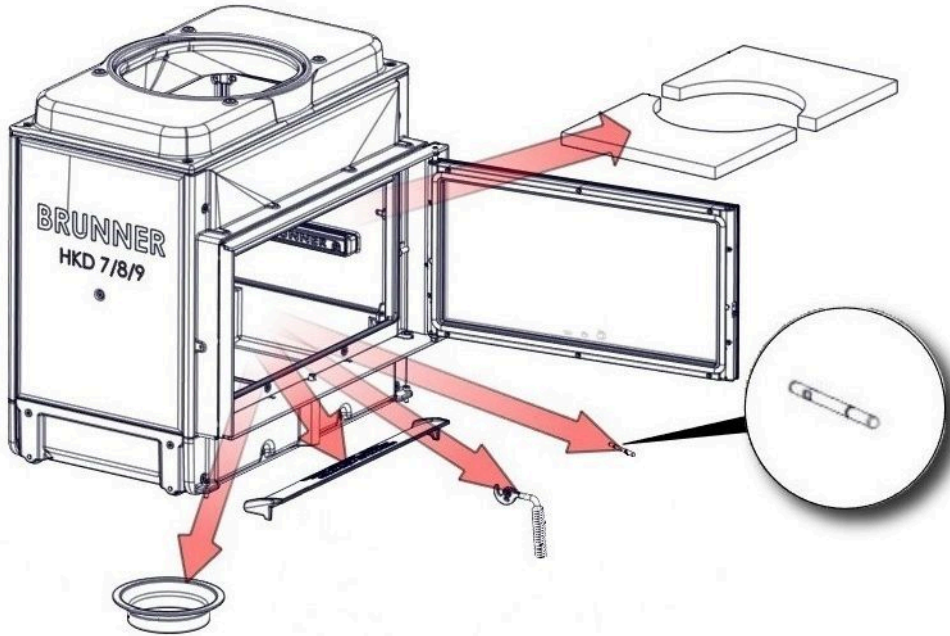

2:

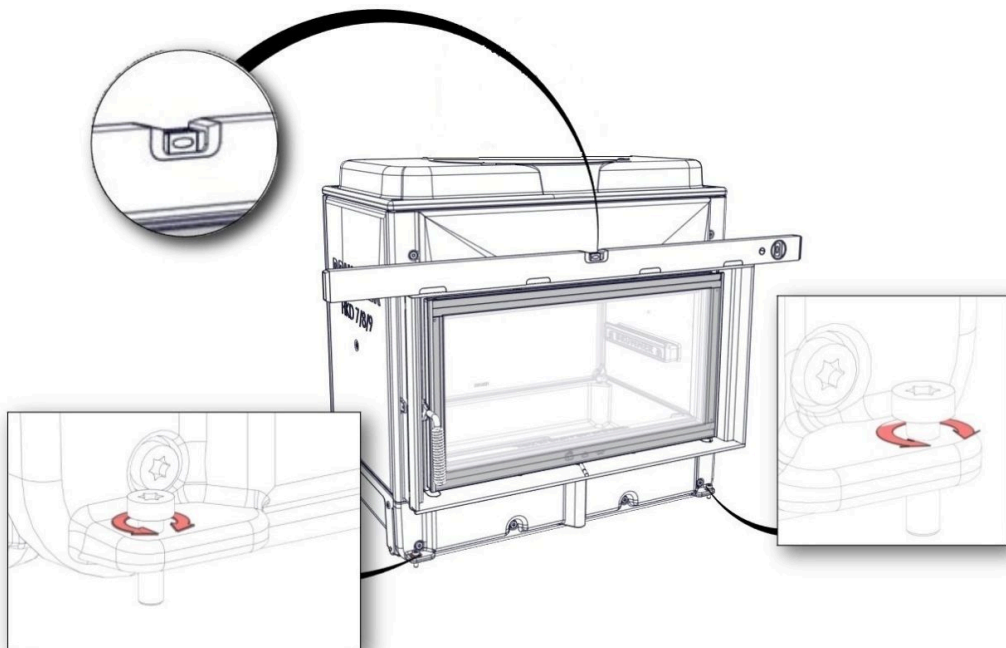

**3:**

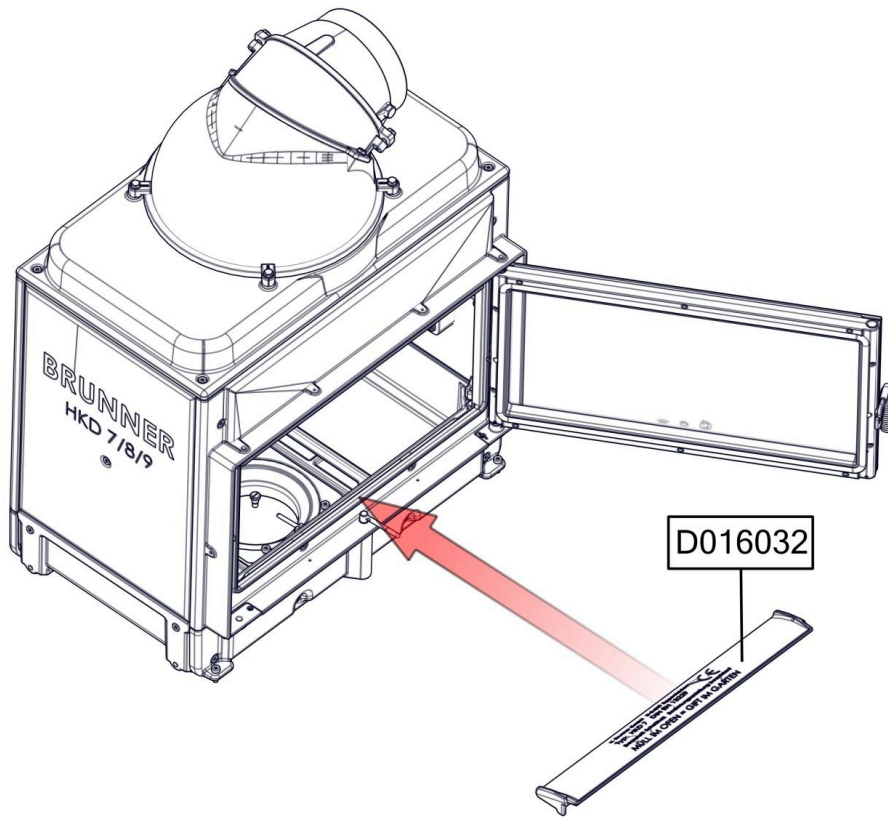

**4:**

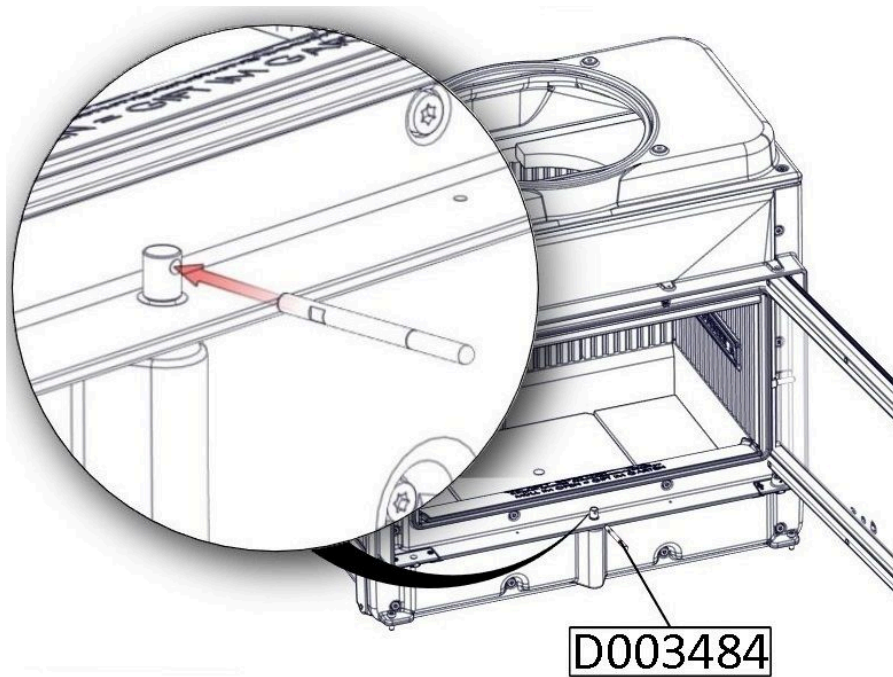



5:

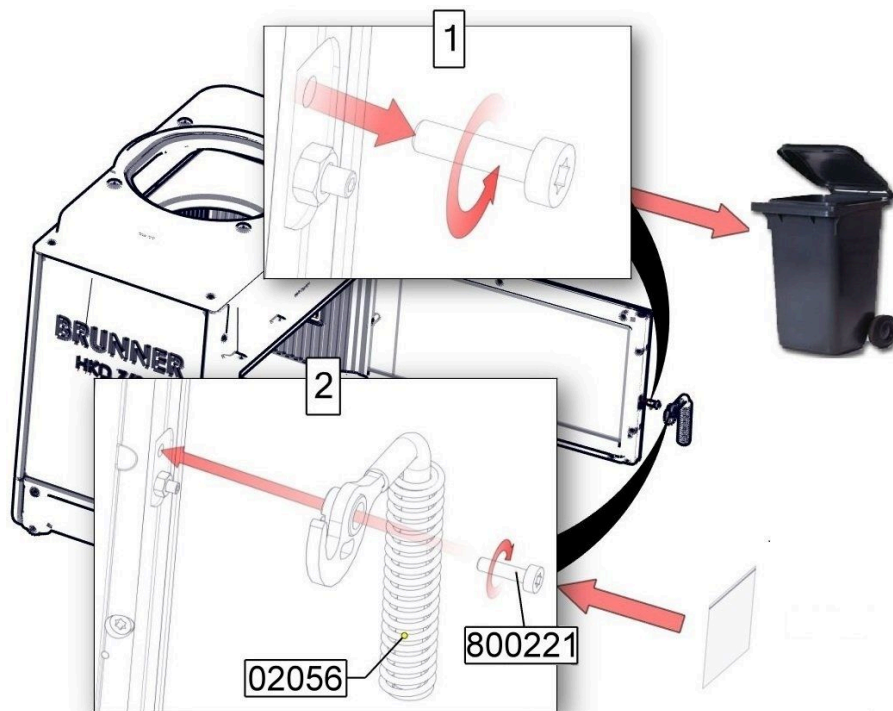

### 6.1 CONNECTION PIECE FOR THE COMBUSTION AIR

1:

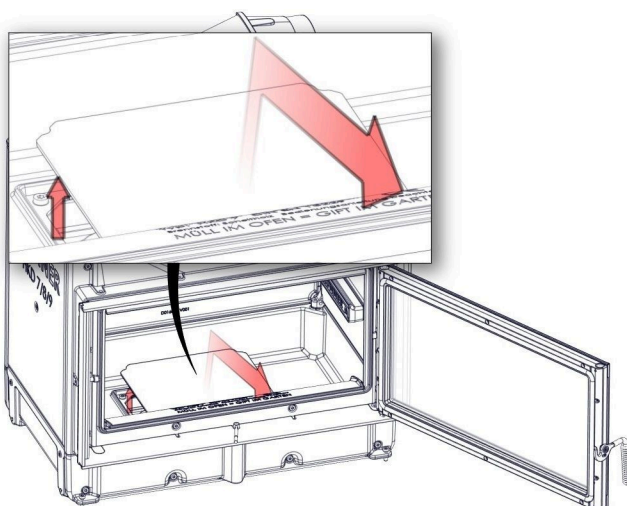

2:

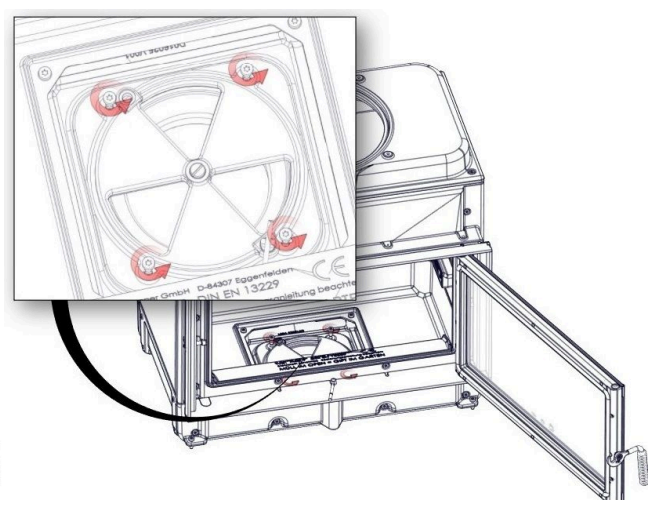

**3:**

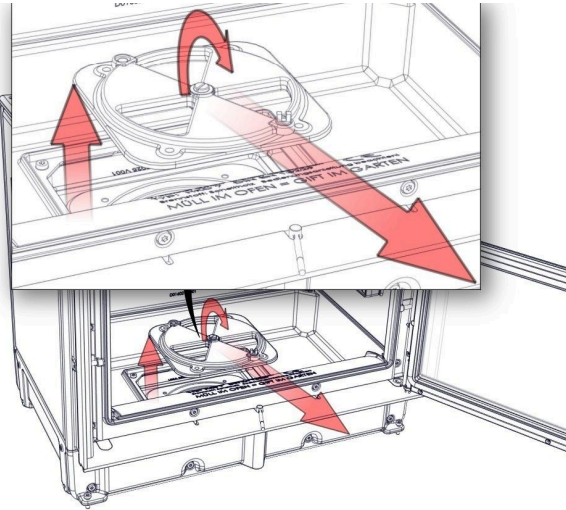

**4:**

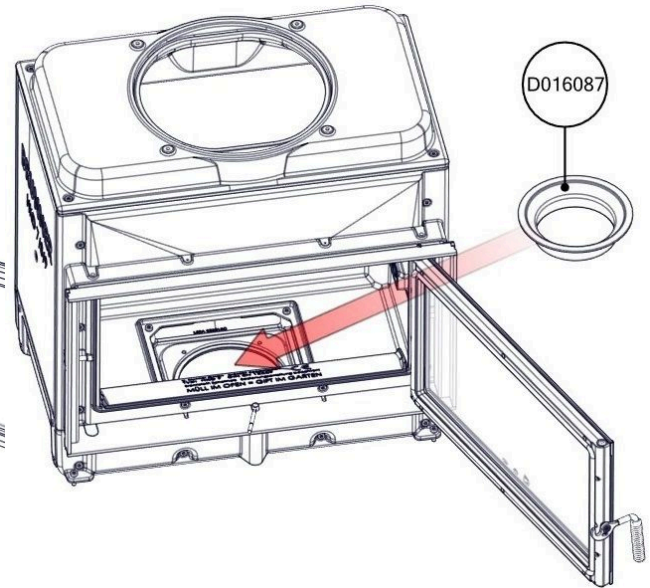

**5:**

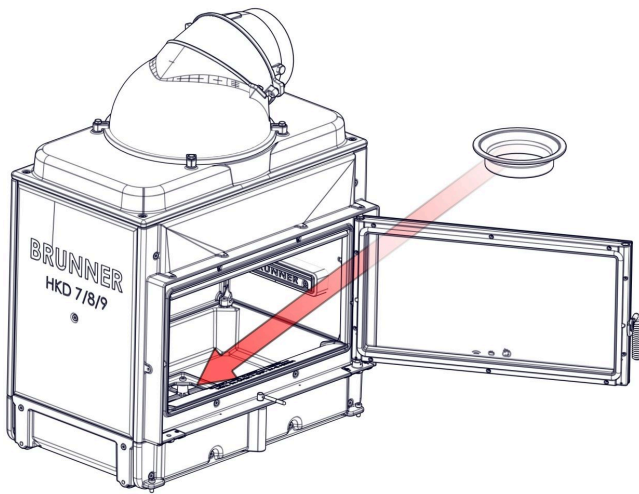

**6:**

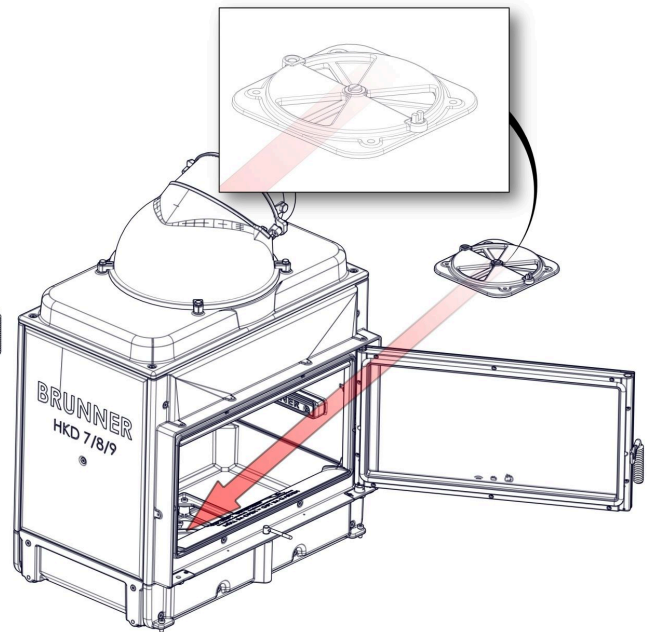

**7:**

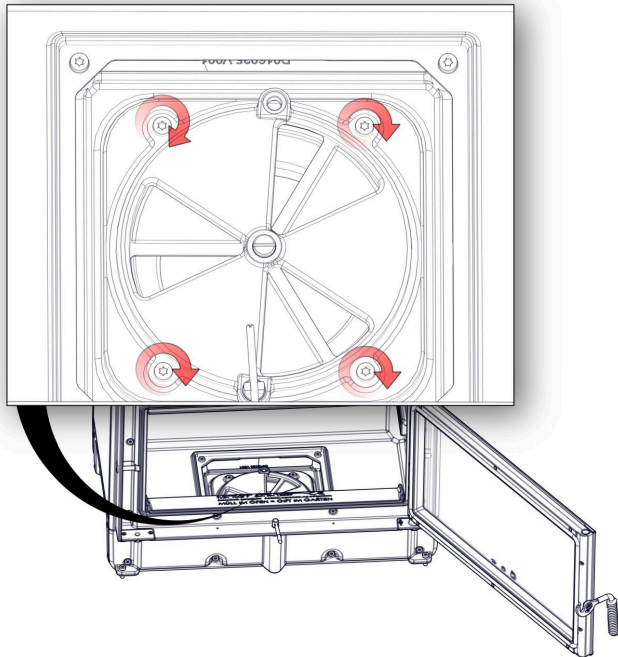

**8:**

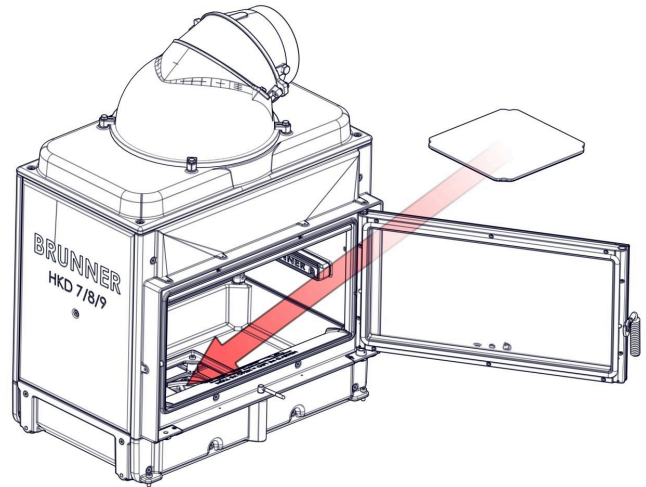

## 6.2 INSTALLATION OF THE FLUE OUTLET

with round dome

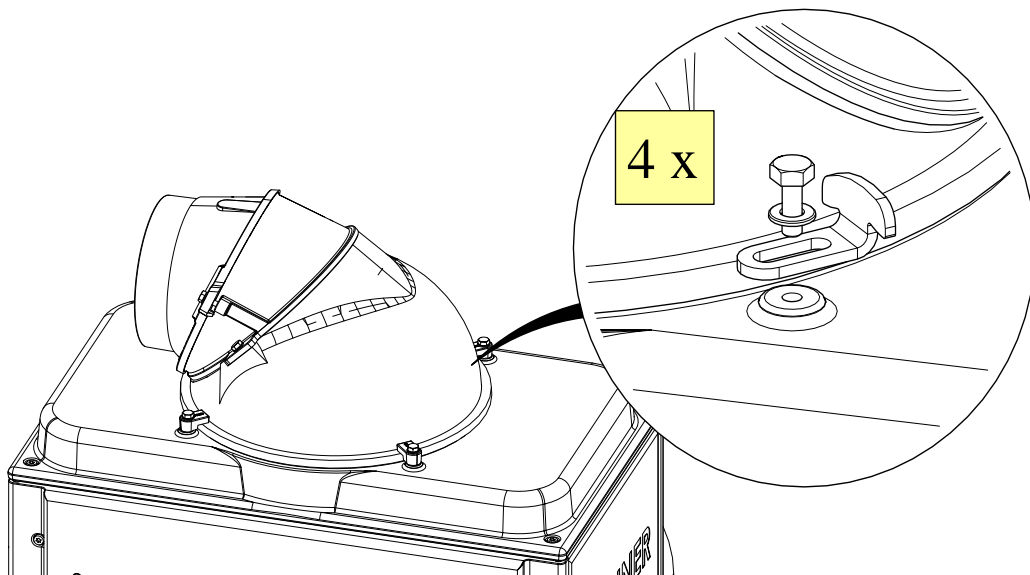

with low dome

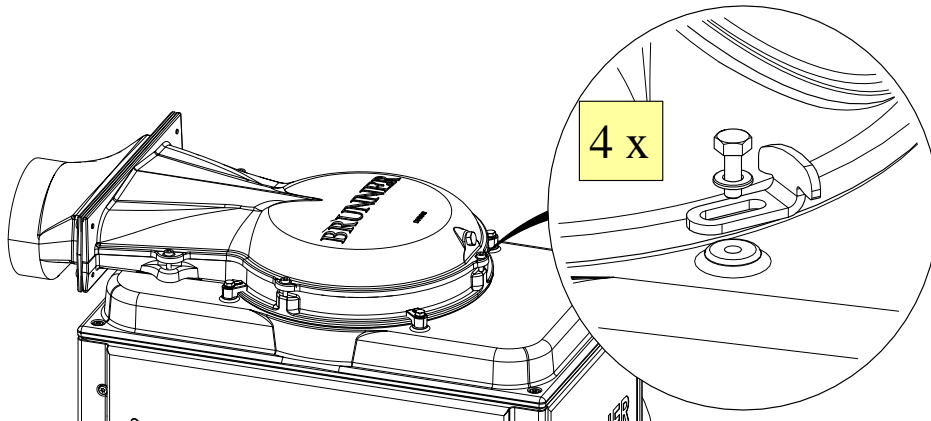

with MAS

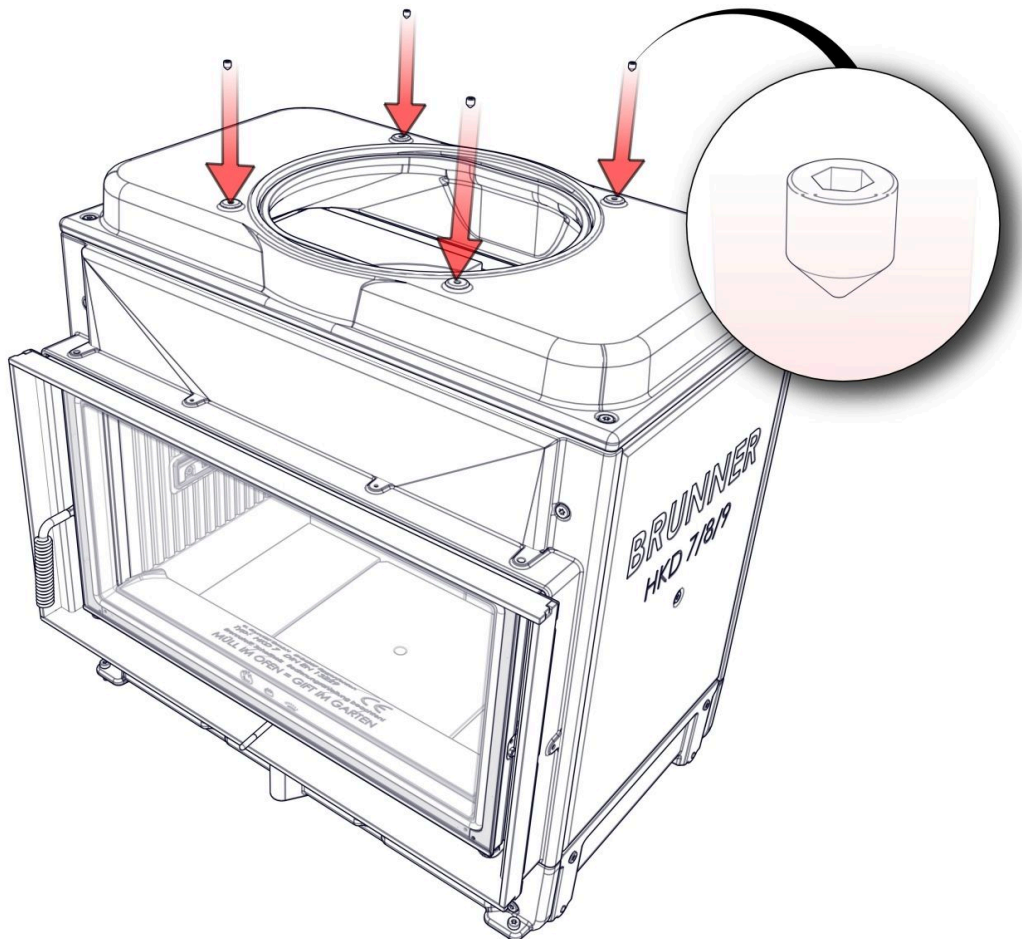

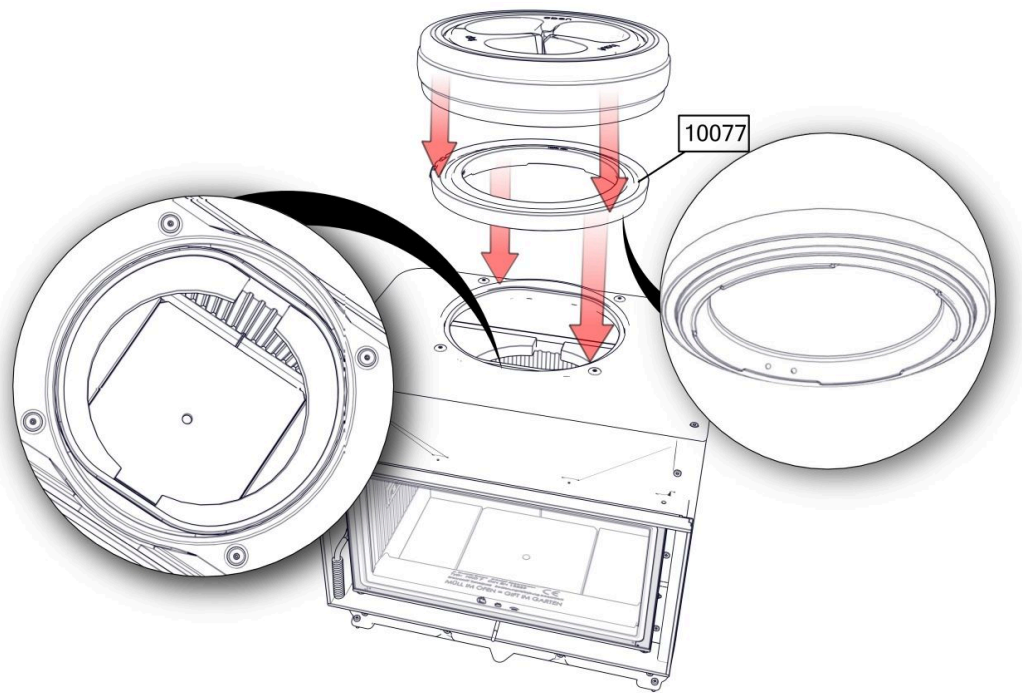

### 6.3 INSTALLATION OF FIRECLAY LINING HKD 7 / 8 / 9

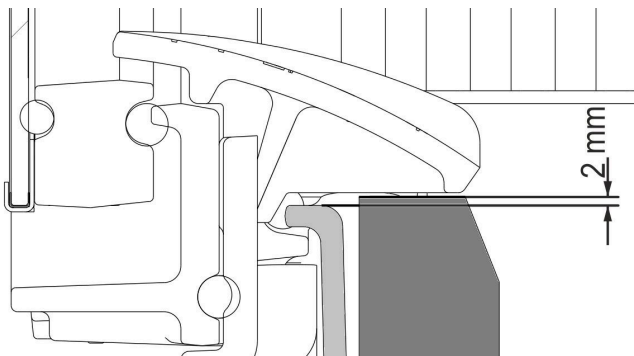
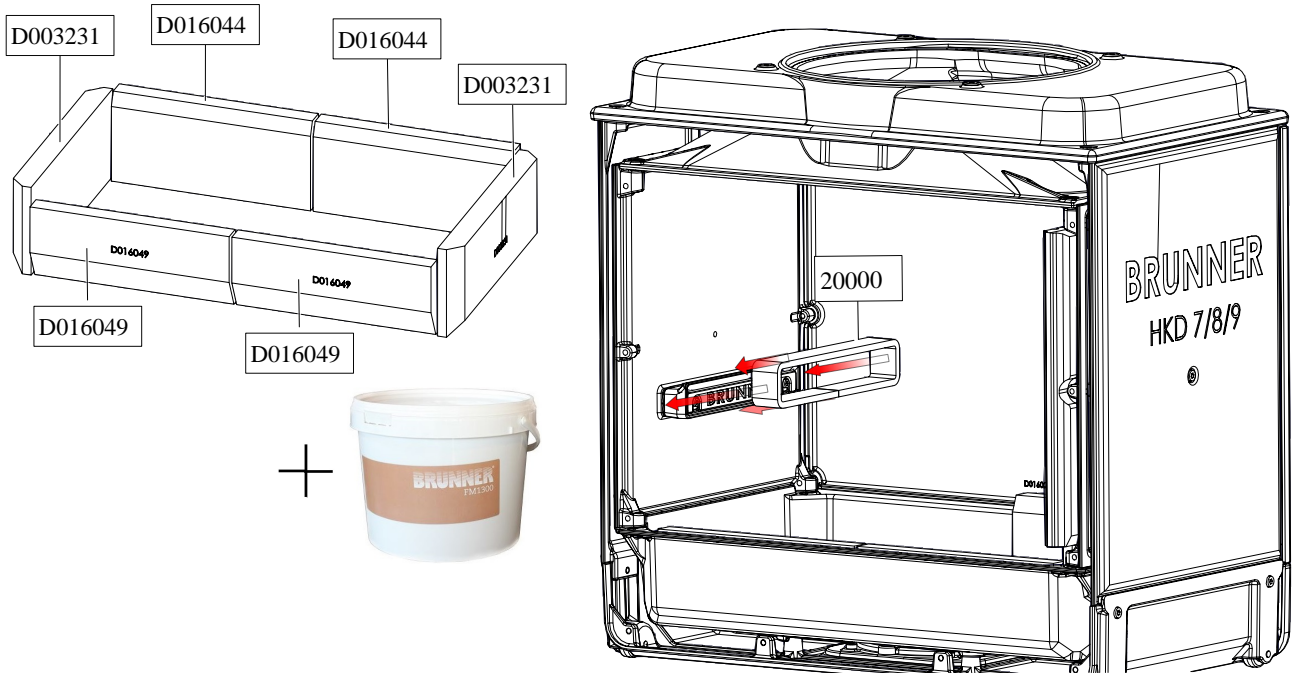

Place the wedge stones so that the upper edge is 2 mm above the floor cast iron plate!

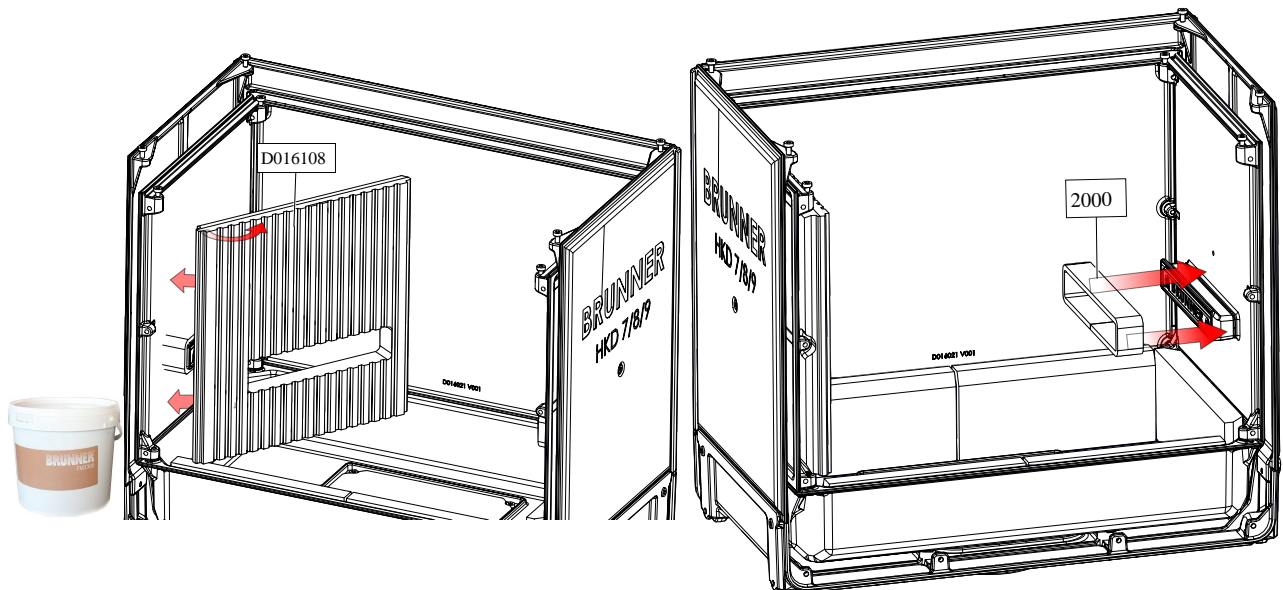

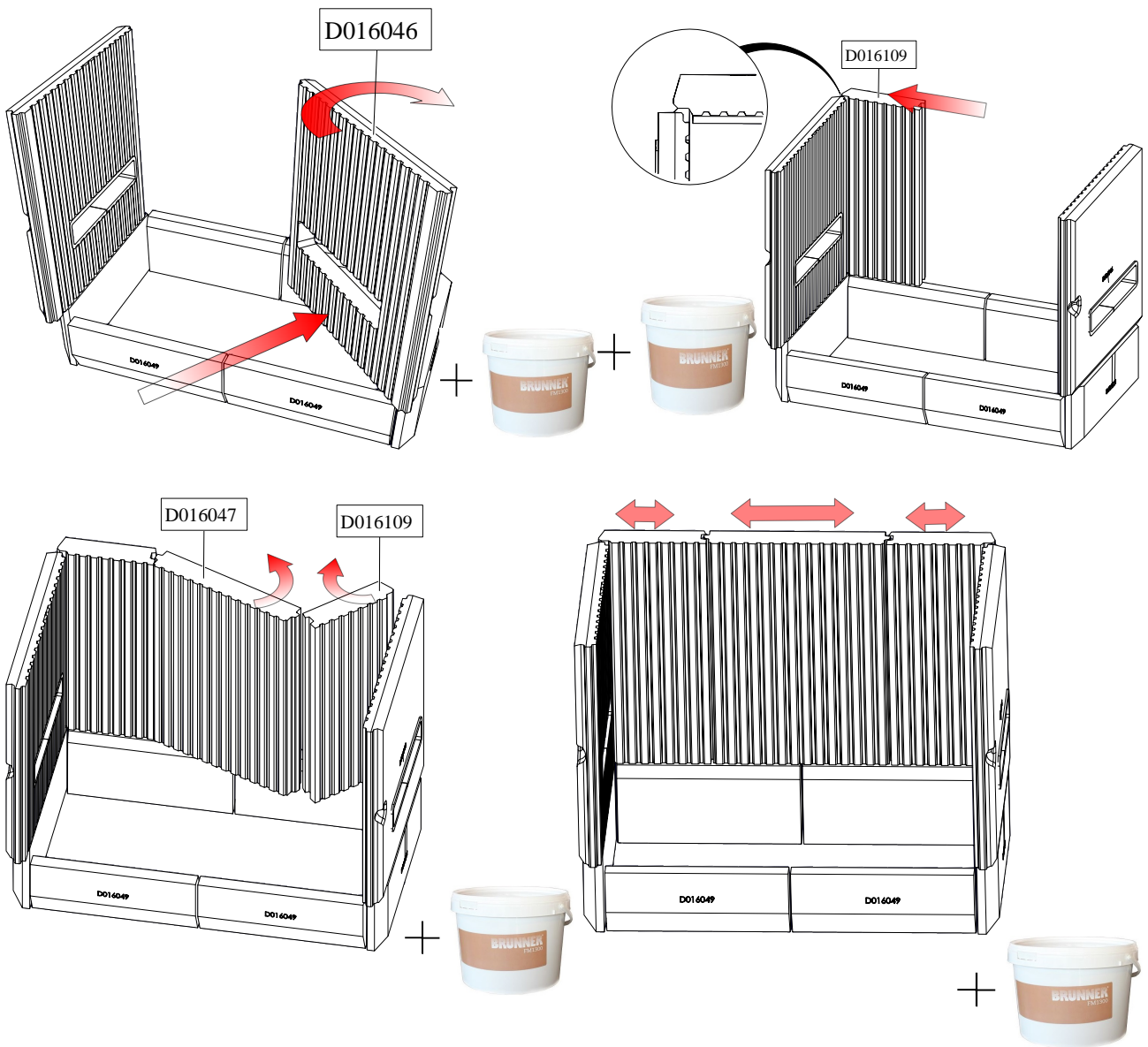

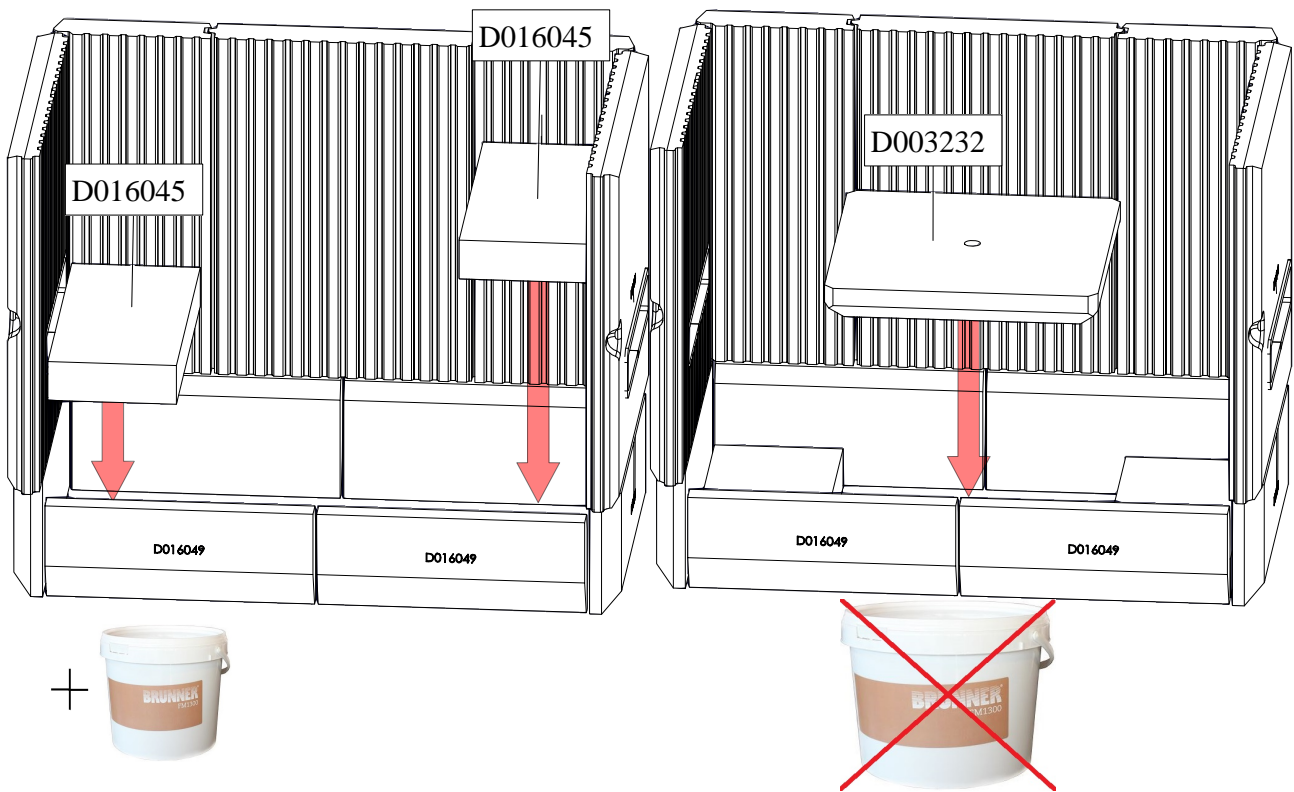

#### 6.4 INSTALLATION FIRECLAY LINING HKD 7 / 8 / 9 DOUBLE FACE

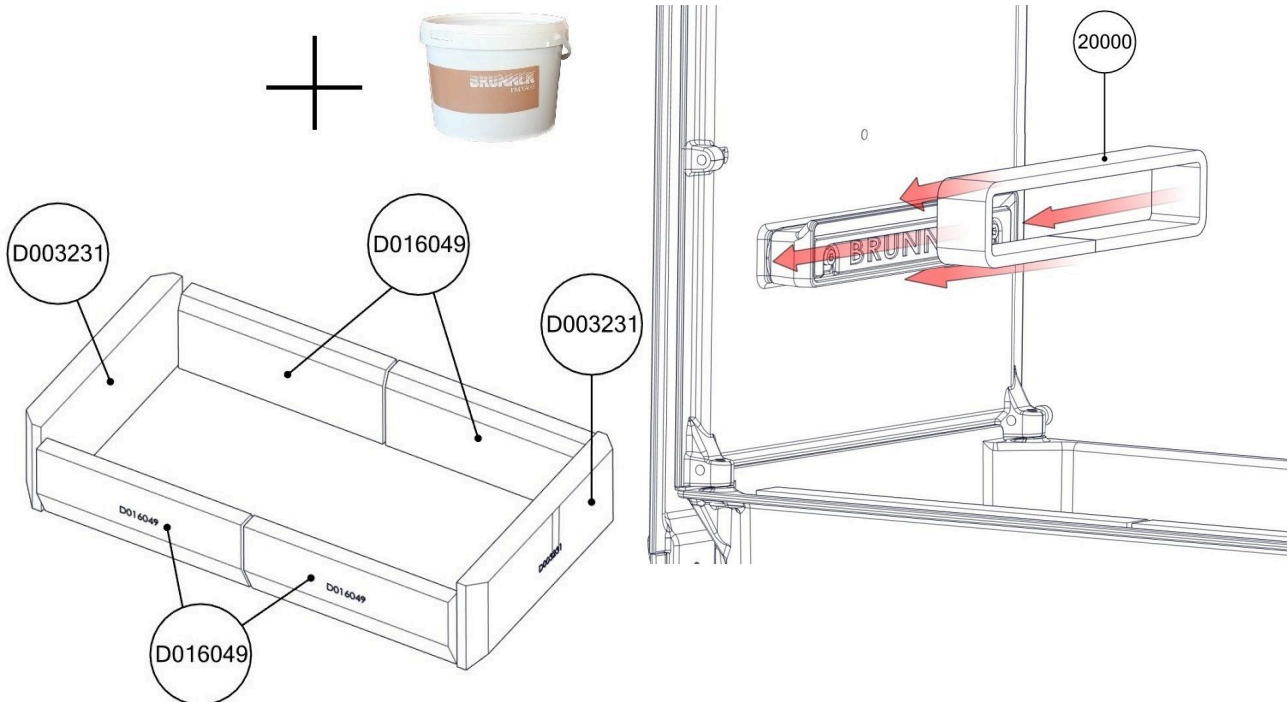



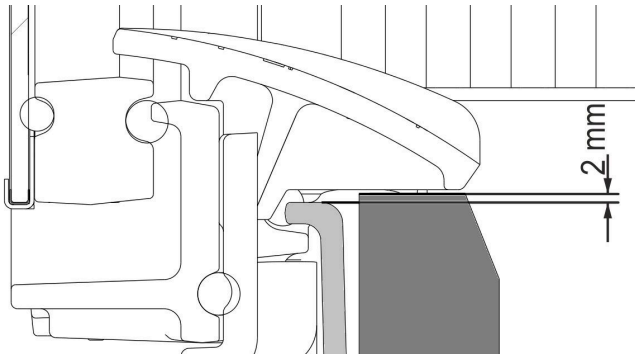

Place the wedge stones so that the upper edge is 2 mm above the floor cast iron plate!

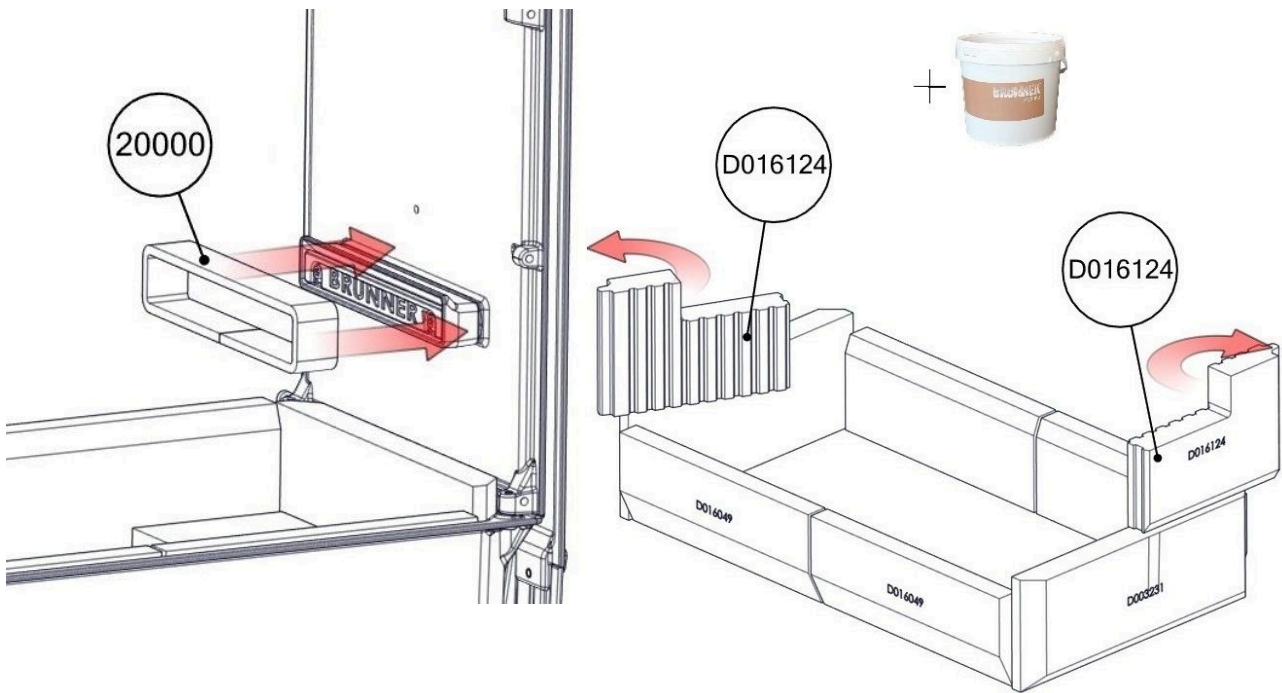

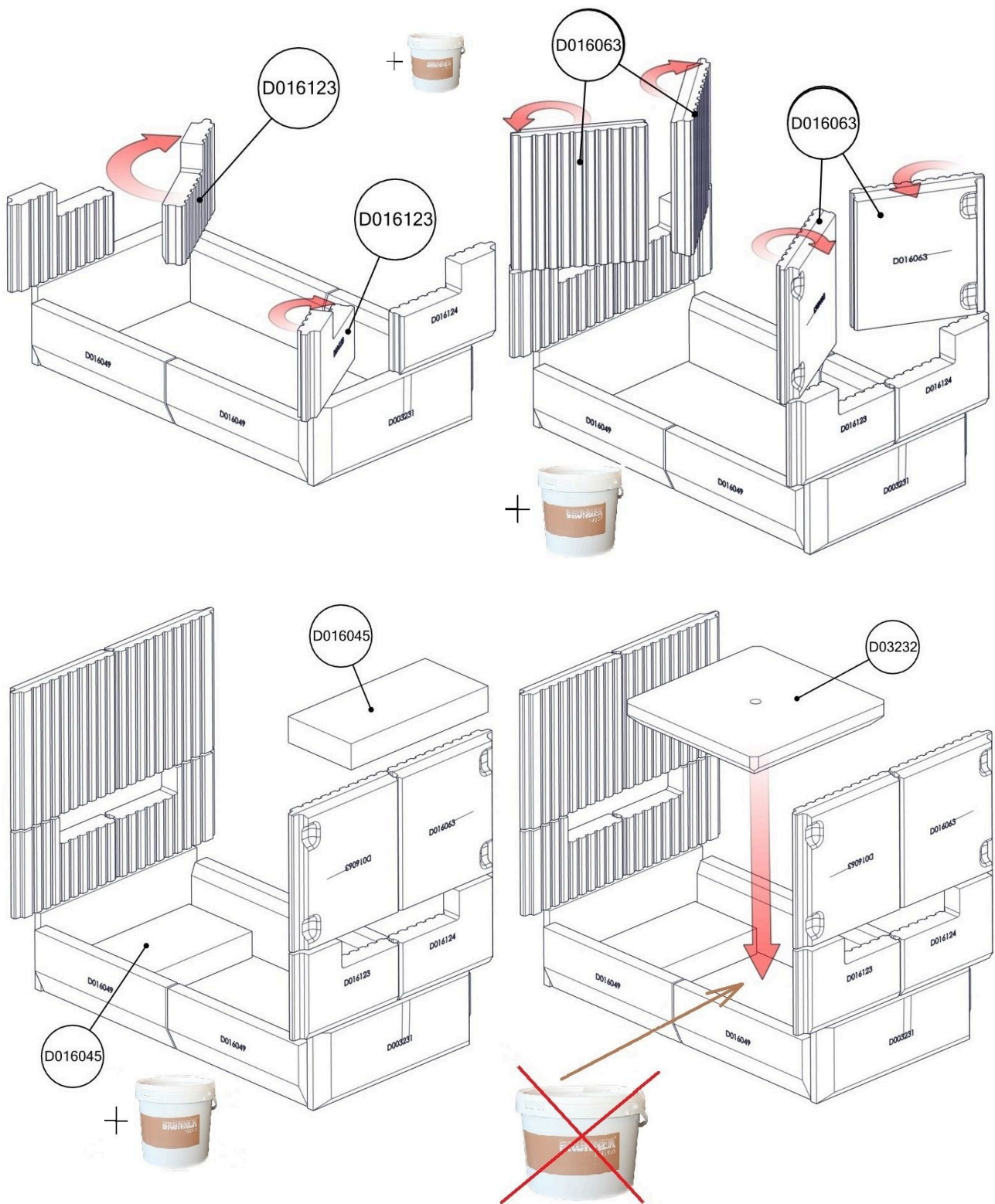

## 6.5 INSTALLATION OF THE DEFLECTOR PLATES

1:

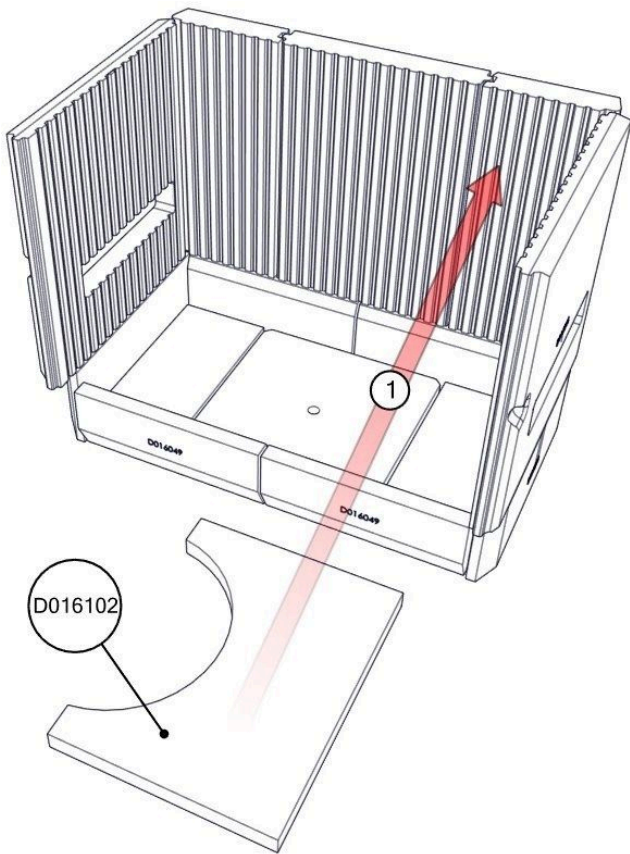

2:

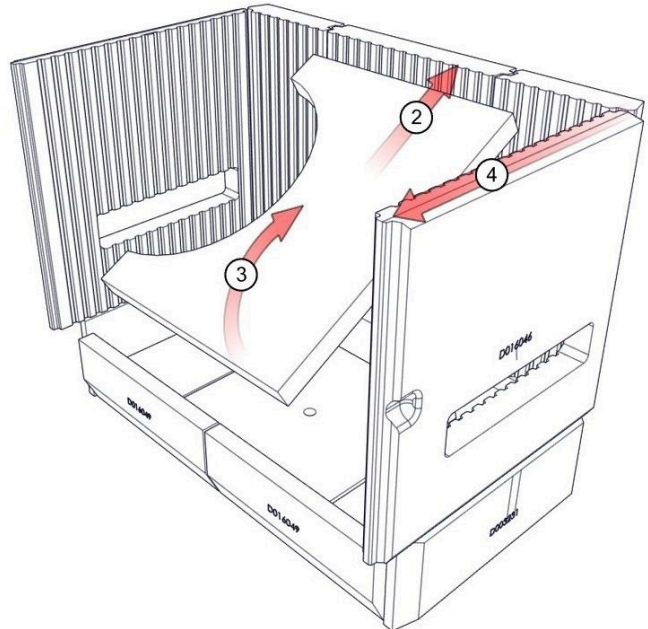

3:

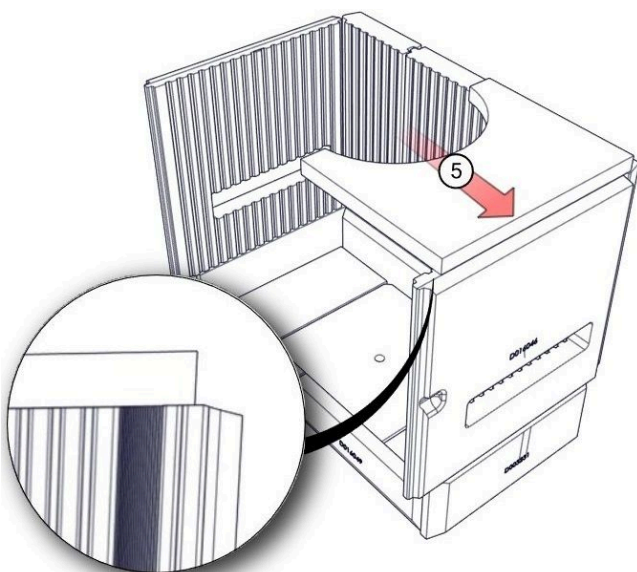

4:

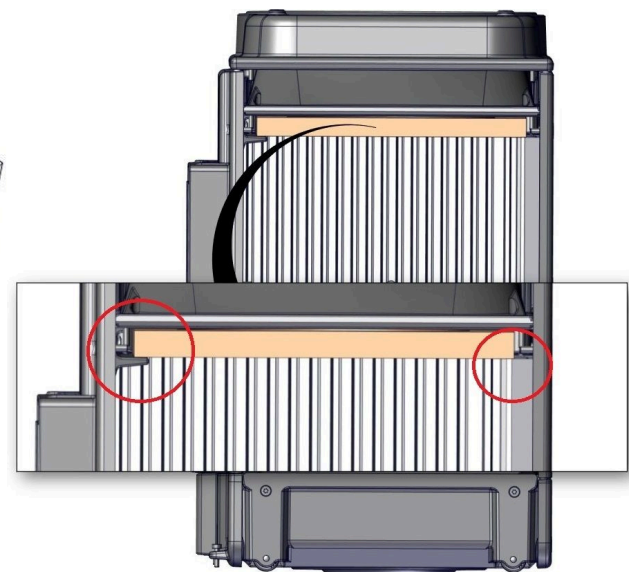

5:

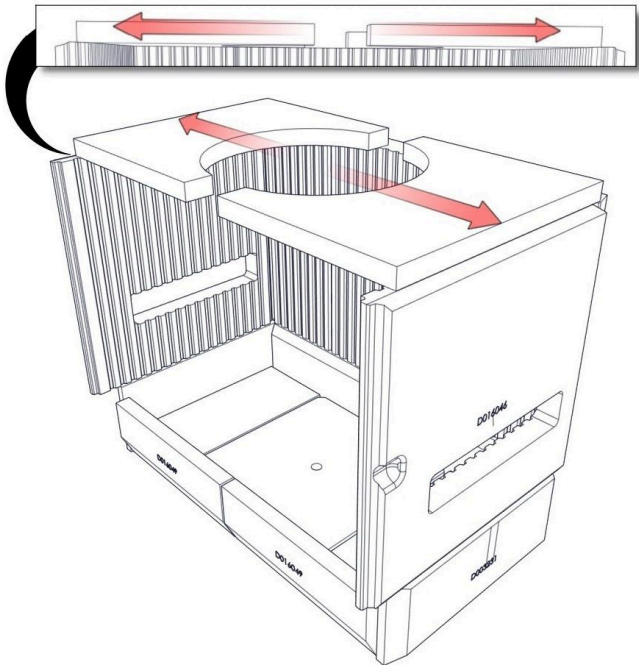

## 6.6 INSTALLATION OF THE MOUNTING FRAME

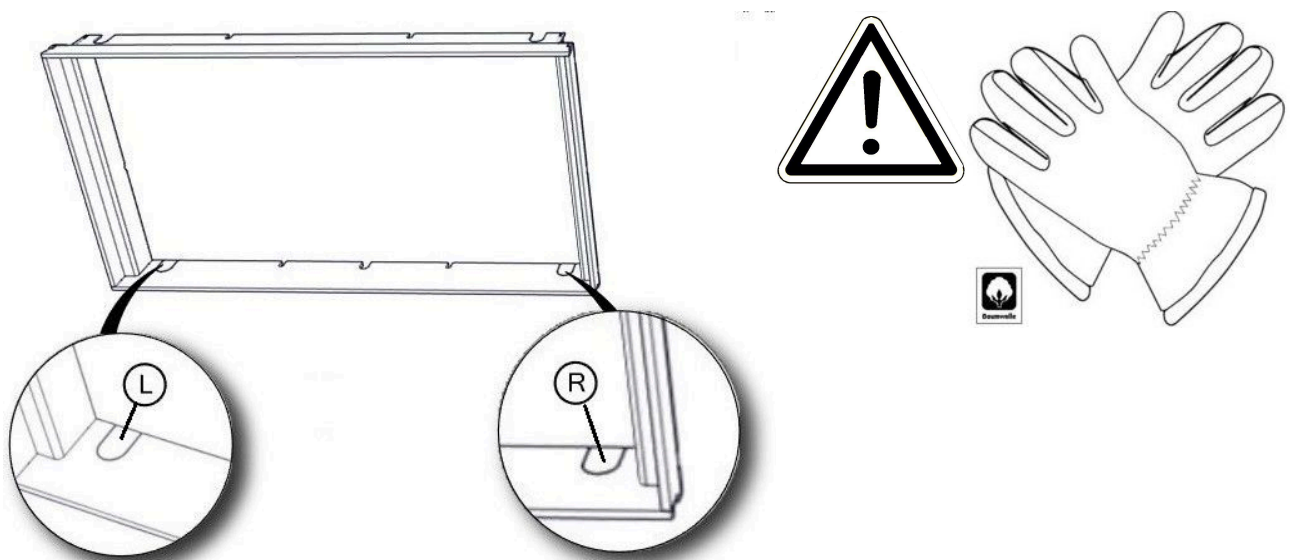

EOS / EAS :

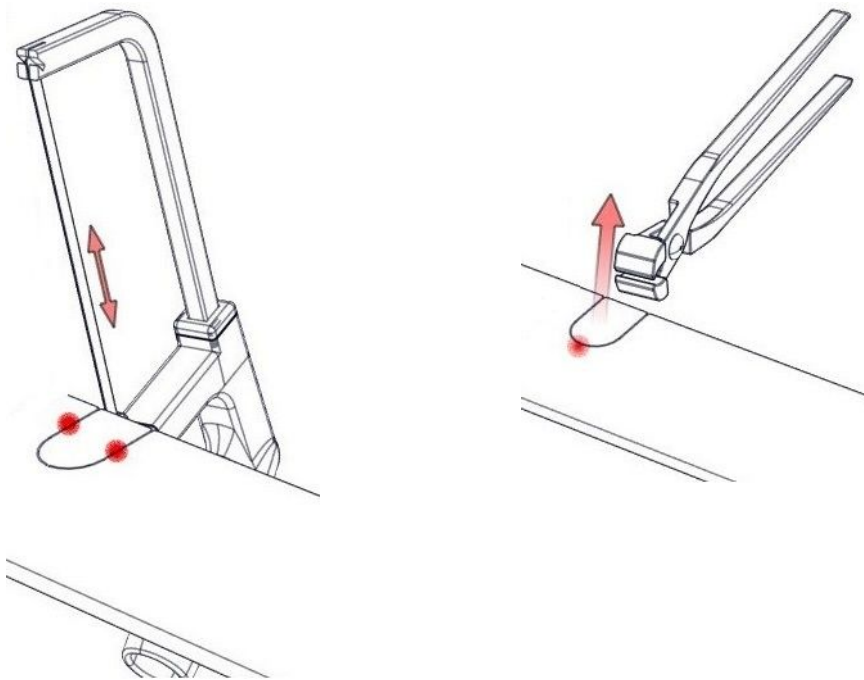
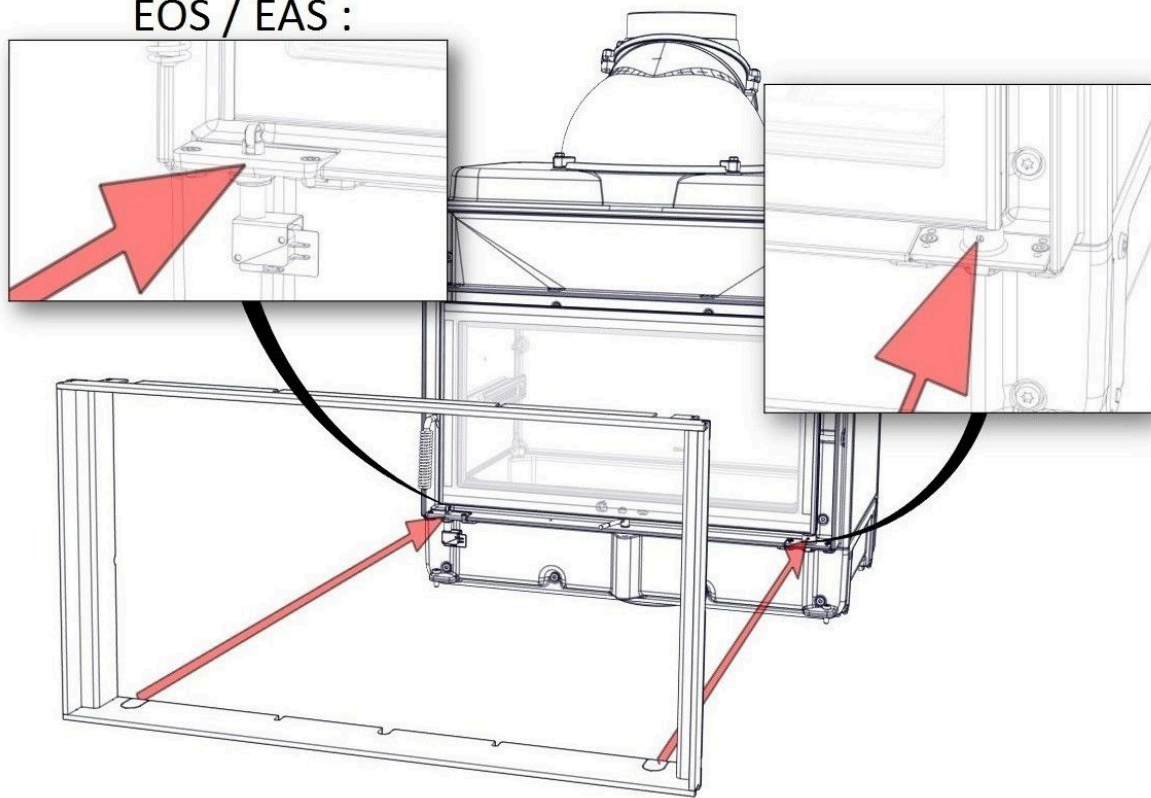

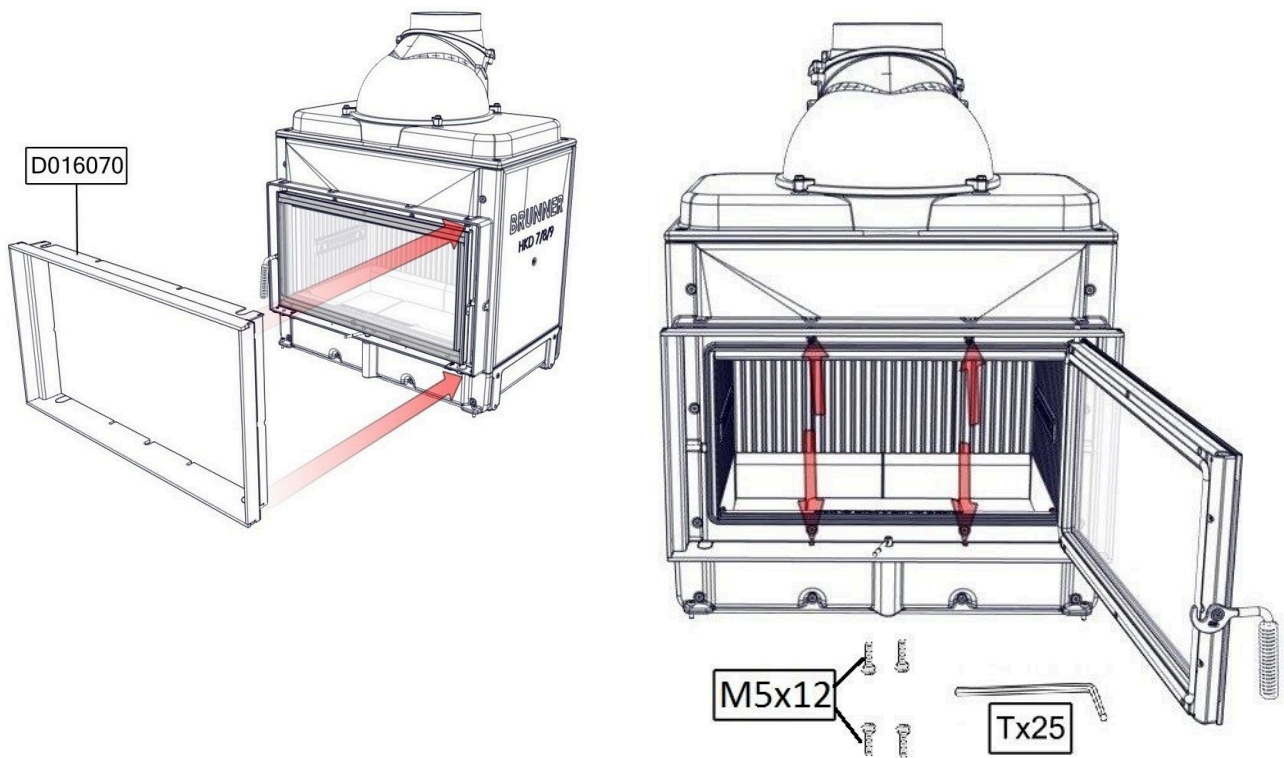

## 6.7 INSTALLATION OF THE DOOR FRAME

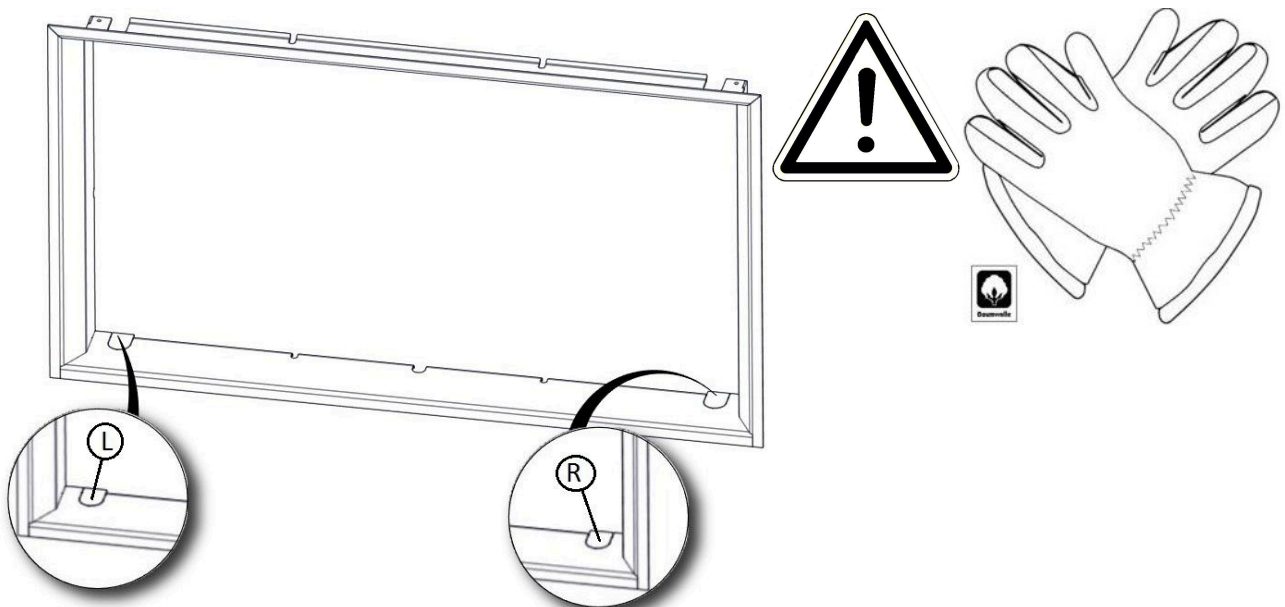

EOS / EAS

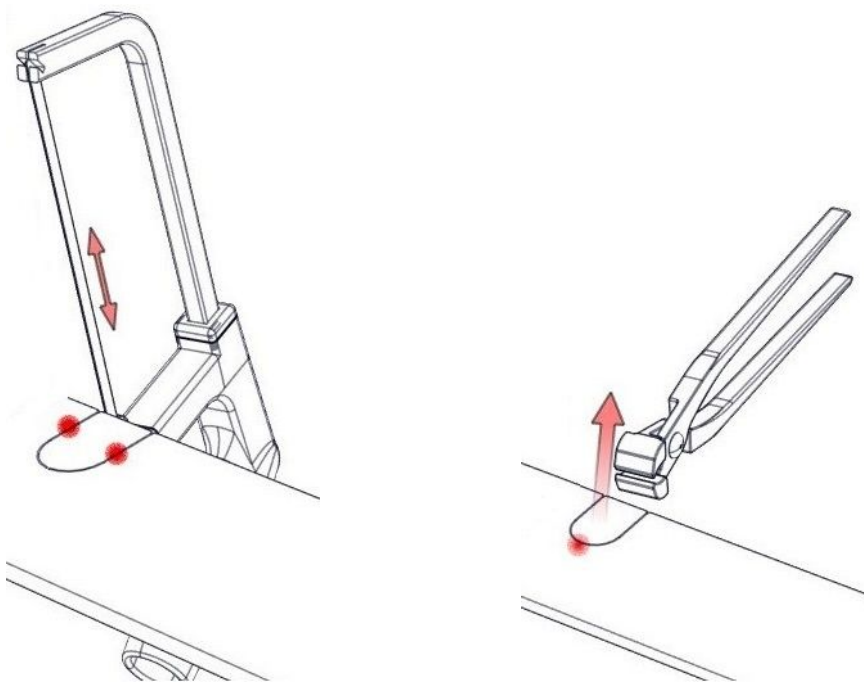
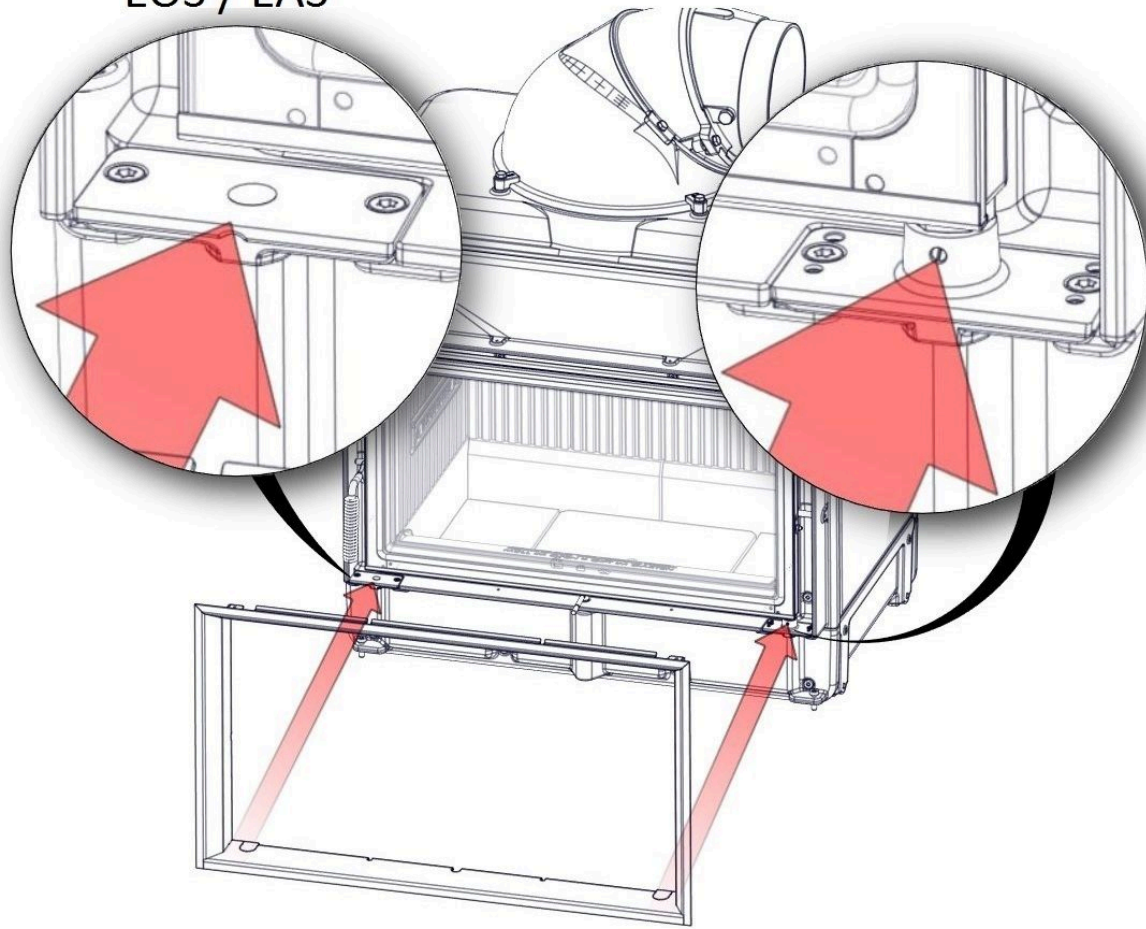

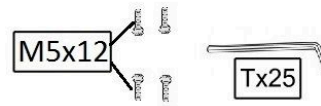
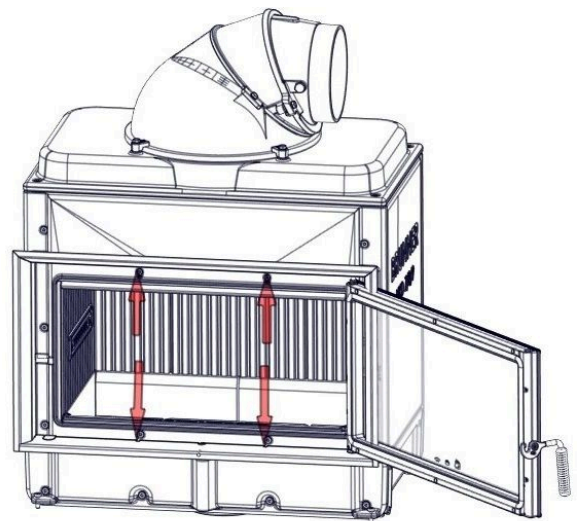
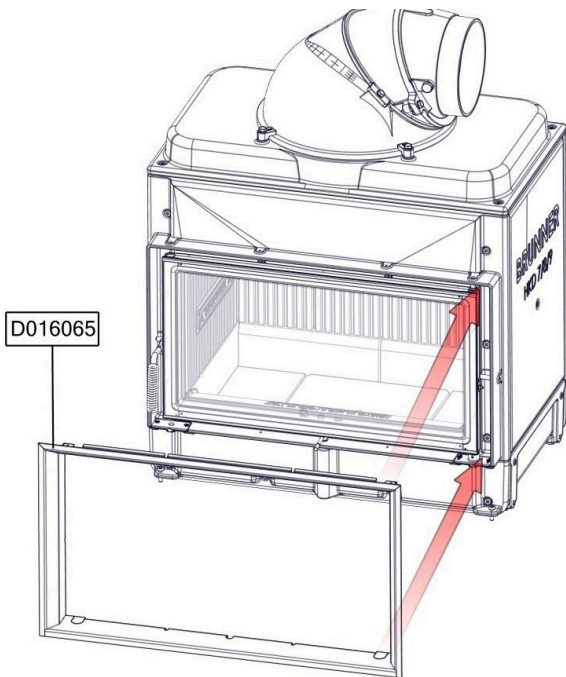



## 7 COMBUSTION AIR SETTING

The combustion air flows into the appliance above the glass and laterally via combustion air nozzles.

These are set at the factory, but should be checked and readjusted if necessary before commissioning the stove.



In order to obtain a symmetrical flame pattern, it is necessary to set columns A, B and C evenly and symmetrically!

Fuel quantity	Gap dimensions for version with one door			Gap dimensions for "tunnel" version (two doors)		
	A	B	C	A	B	C
3 kg - 8 kg*	6	2	2	4	2	2
8 kg - 12 kg**	8	2	2	6	2	2

\*delivery level / \*\*storage loading

**Setting the windshield purge air:**

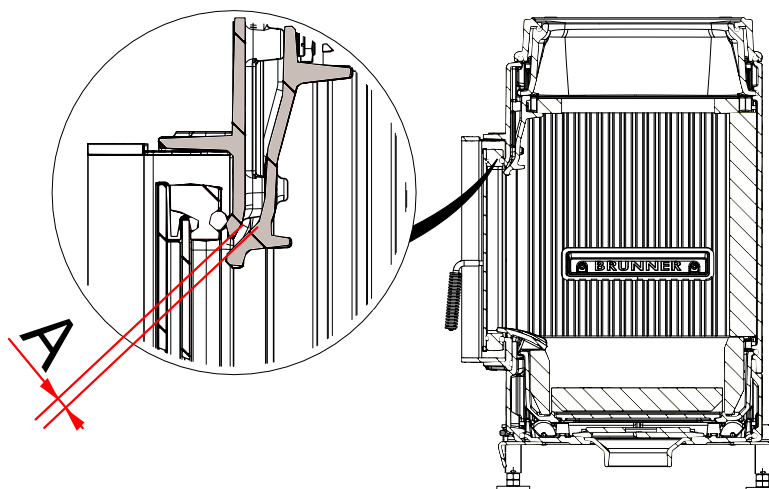

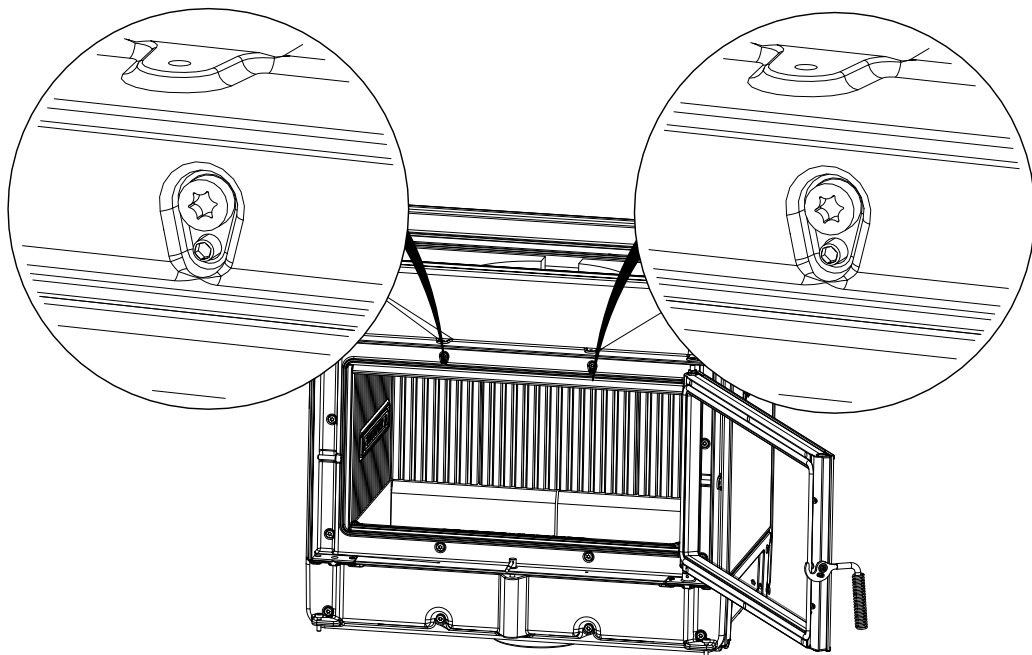
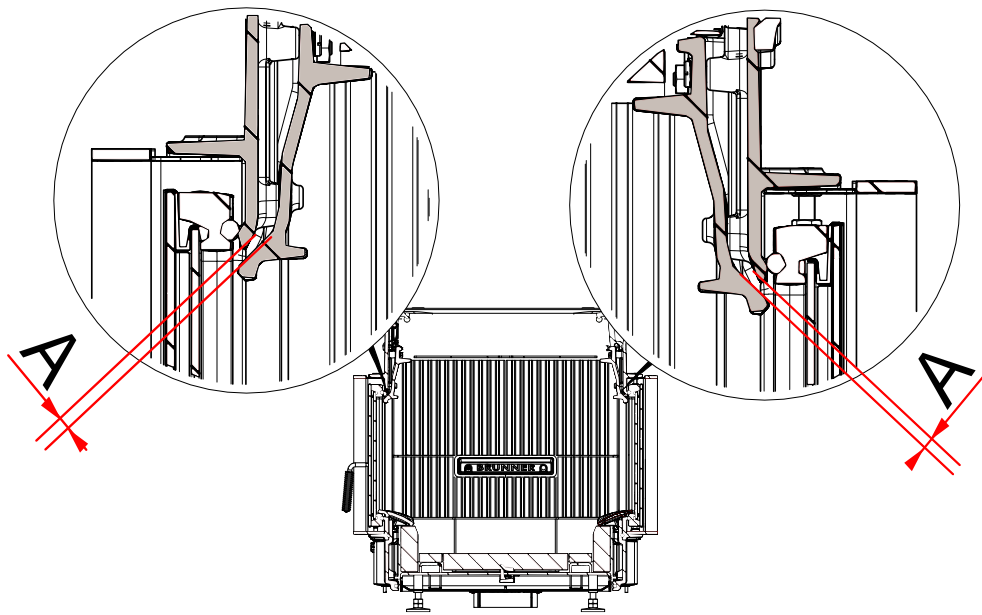

**A >**

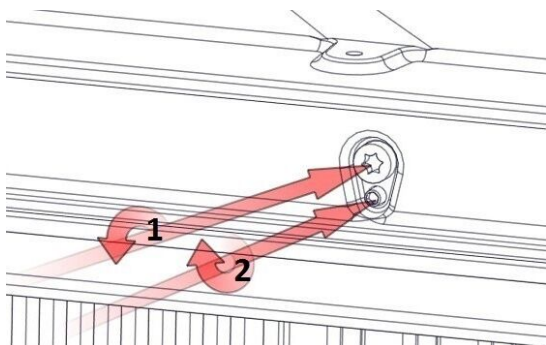

**A <**

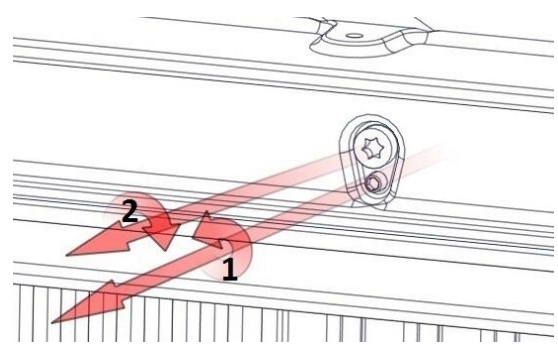

**Adjusting the side combustion air nozzles:**

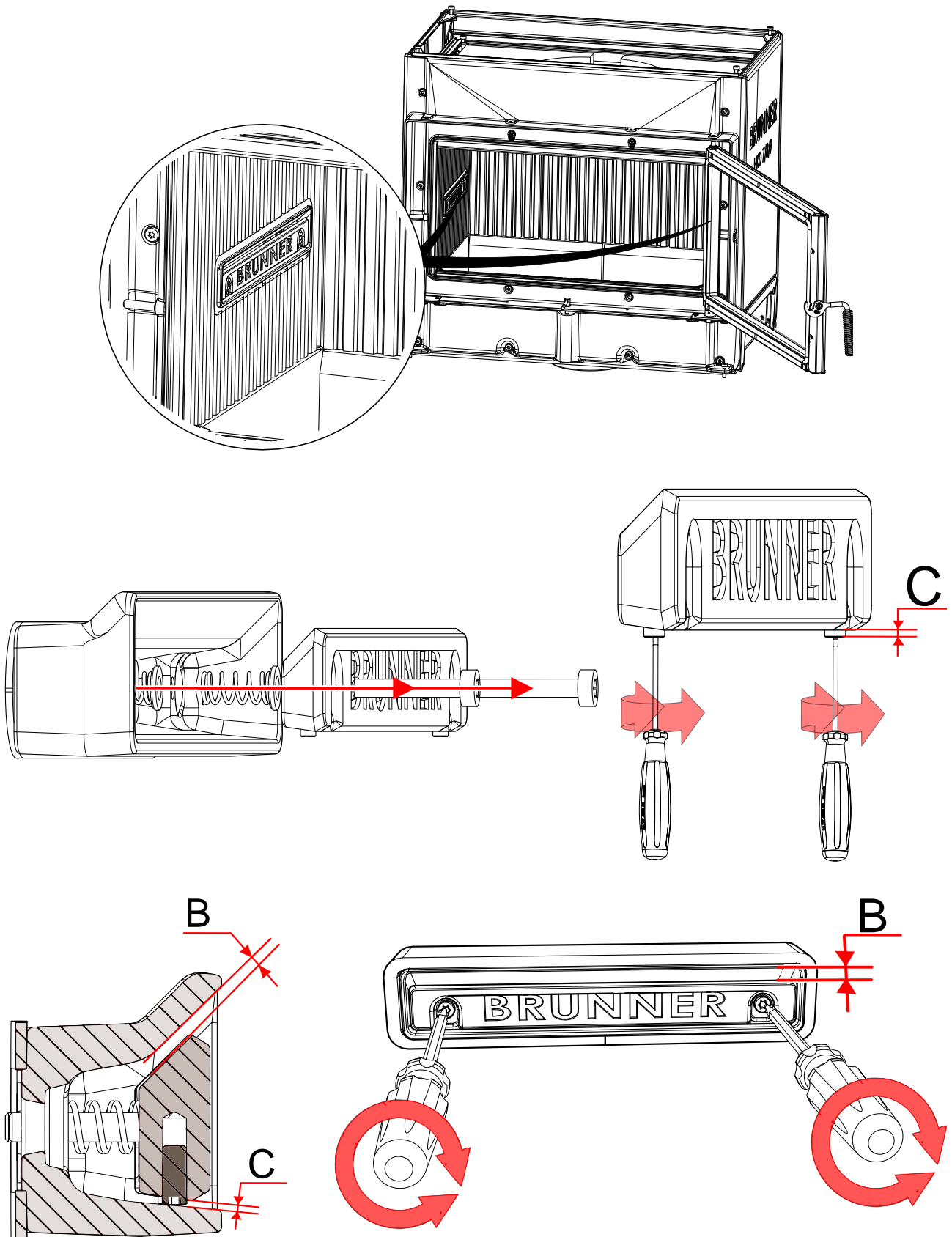

## 8 SETTING OF SELF-CLOSING MECHANISM

1:

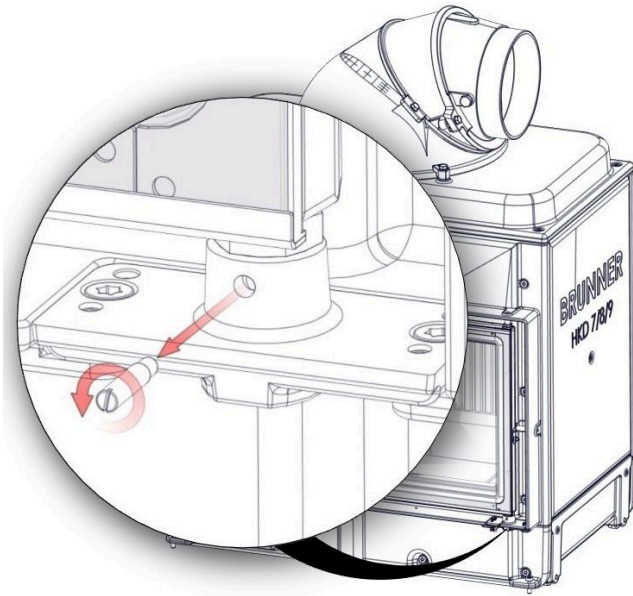

2:

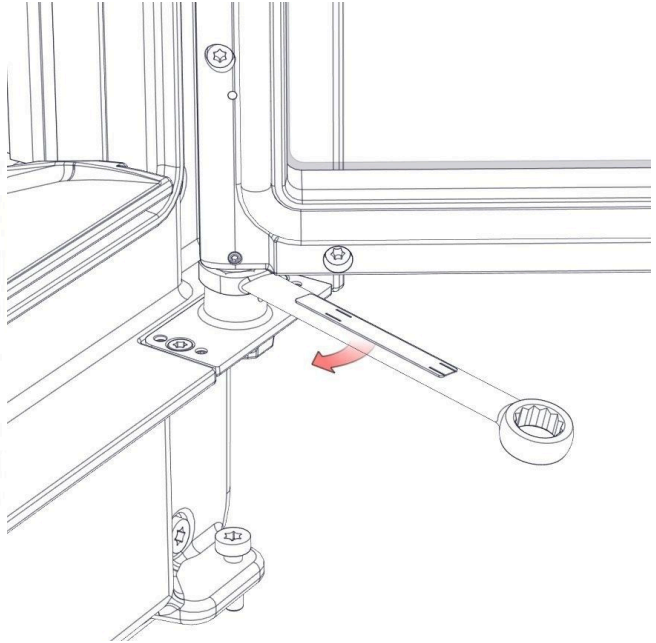

3:

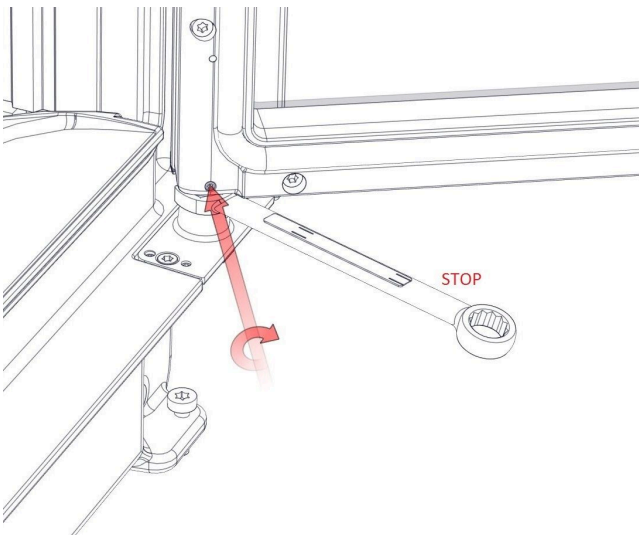

4:

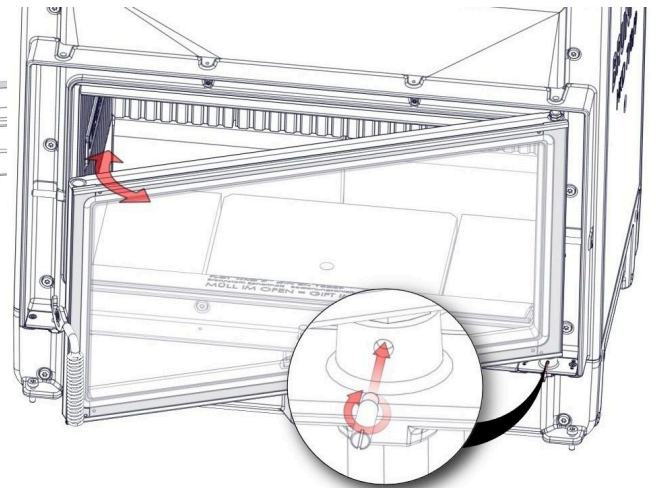

**5:**

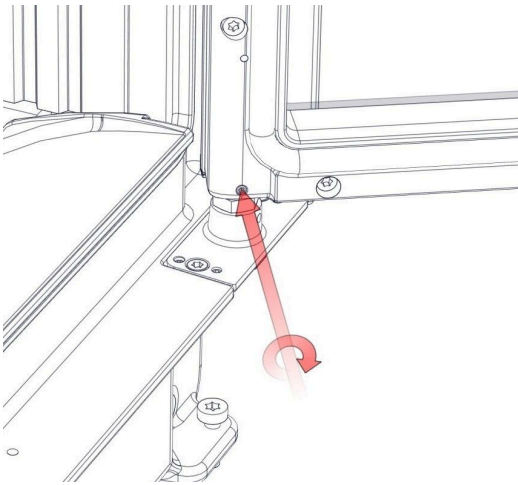

**6:**

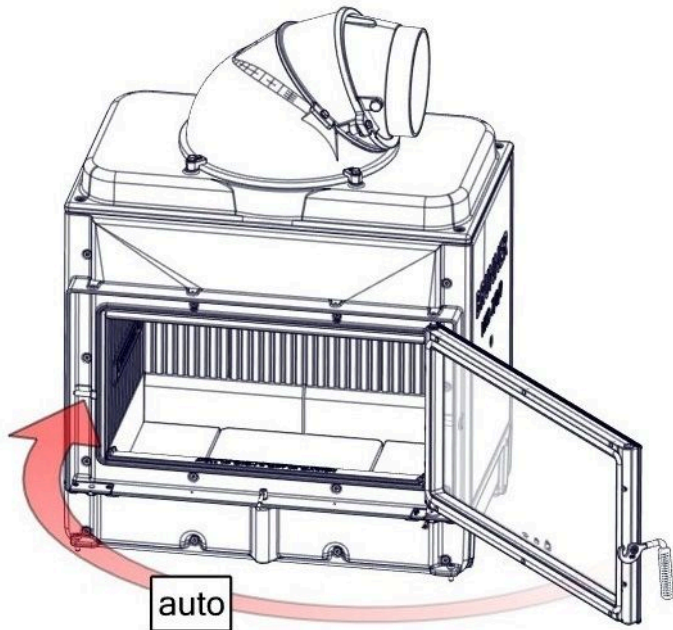

## **9 CONVERSION OF THE DOOR HINGE**

**1:**

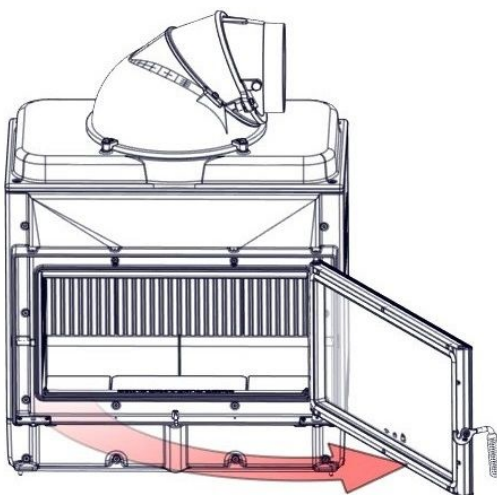

**2:**

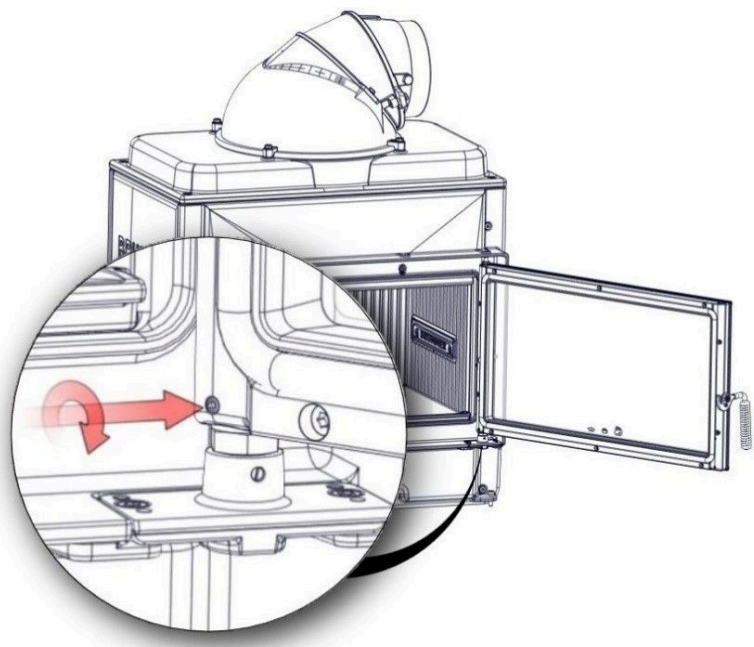

**3:**

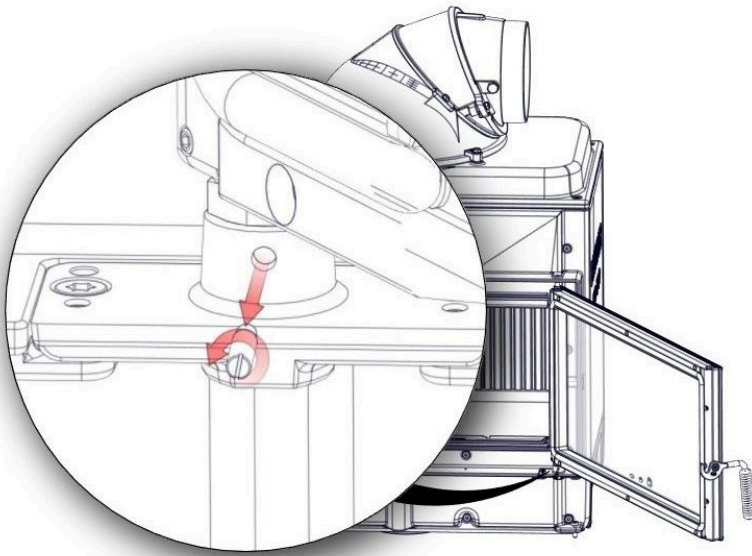

**4:**

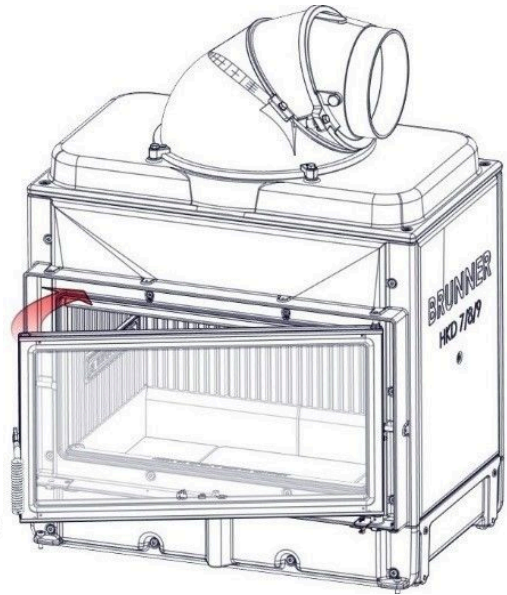

**5:**

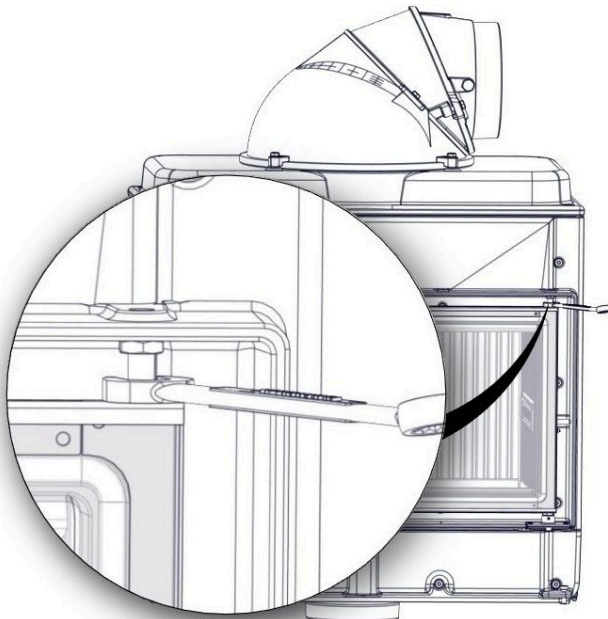

**6:**

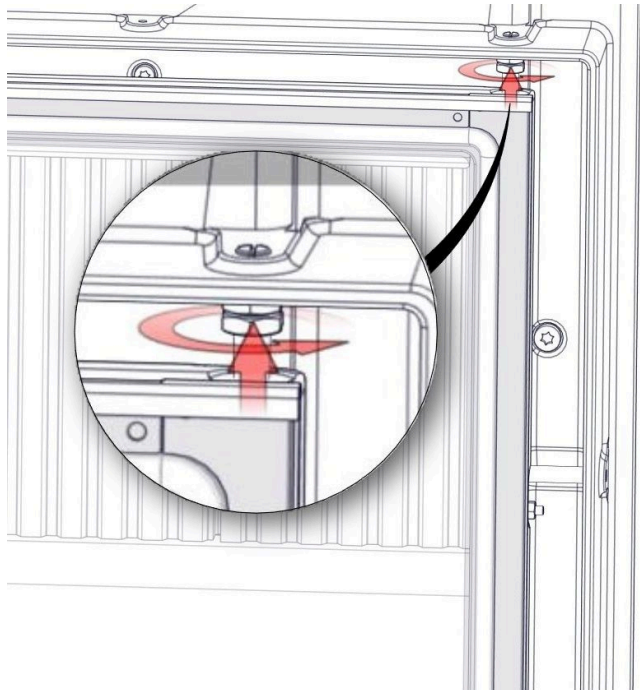

7:

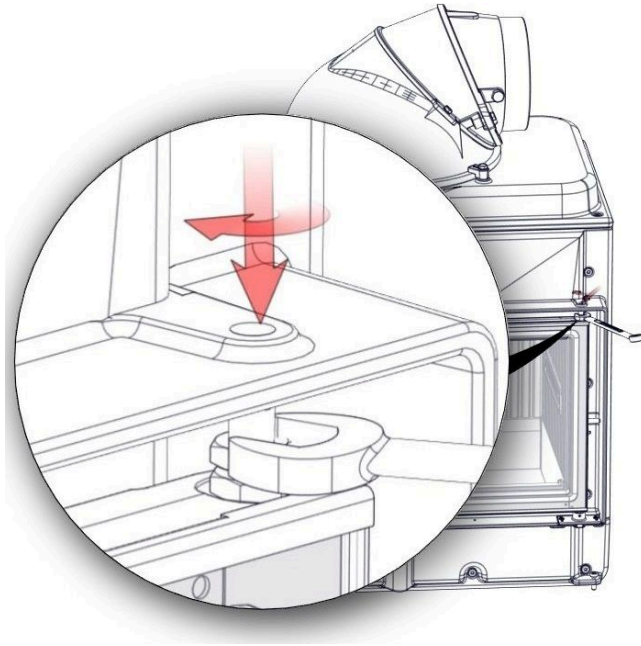

8:

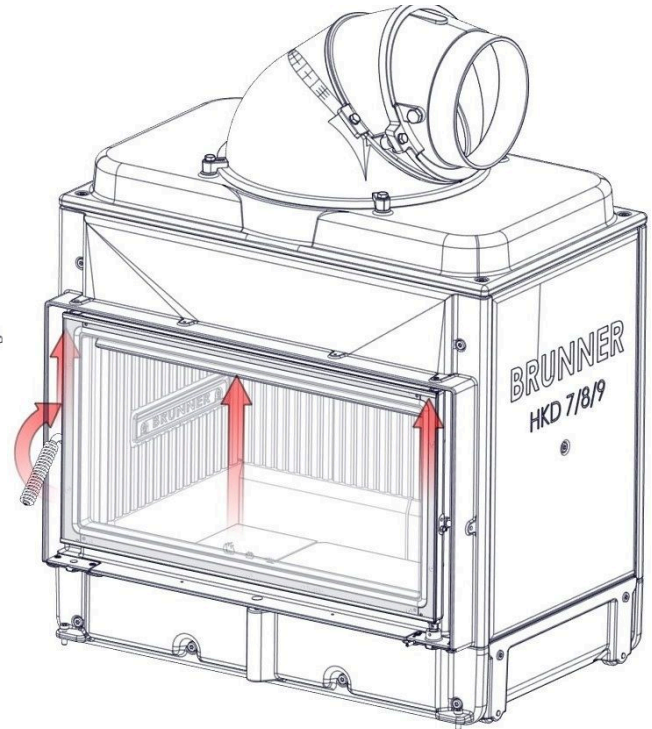

9:

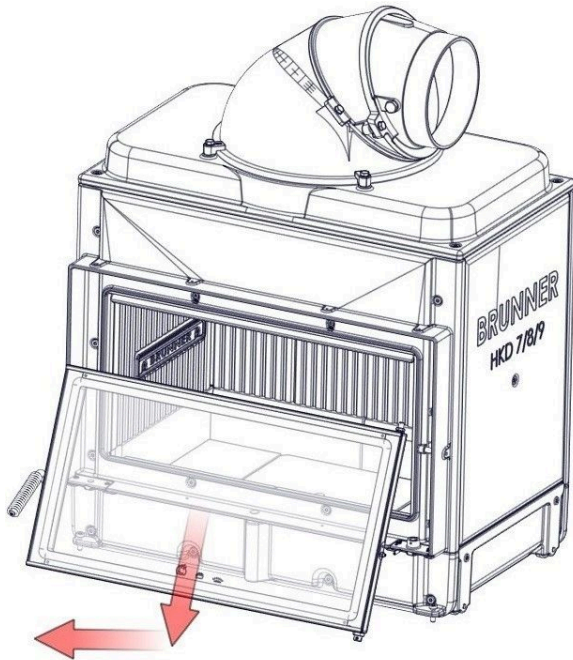

10:

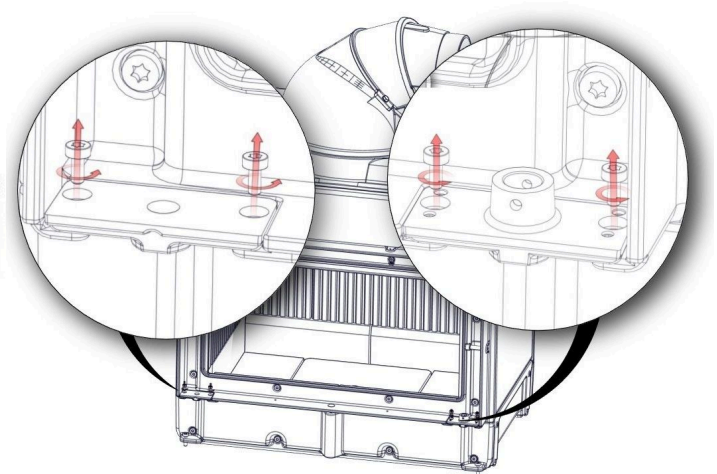

**11:**

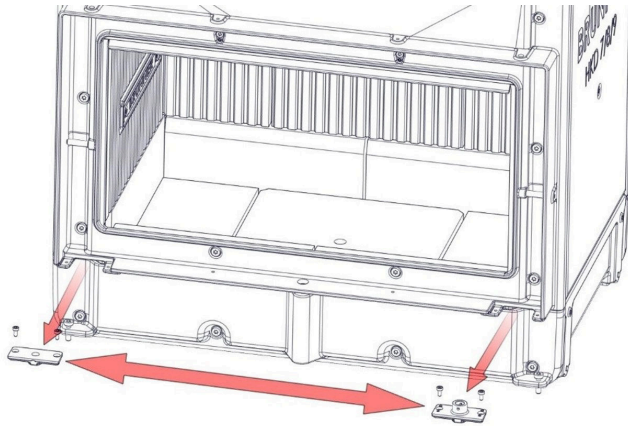

**12:**

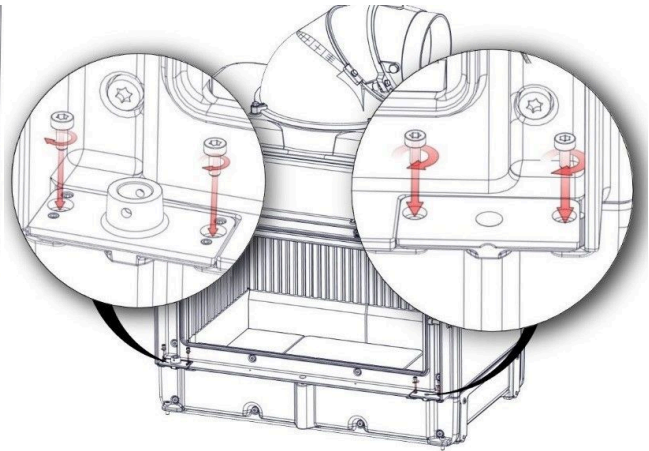

**13:**

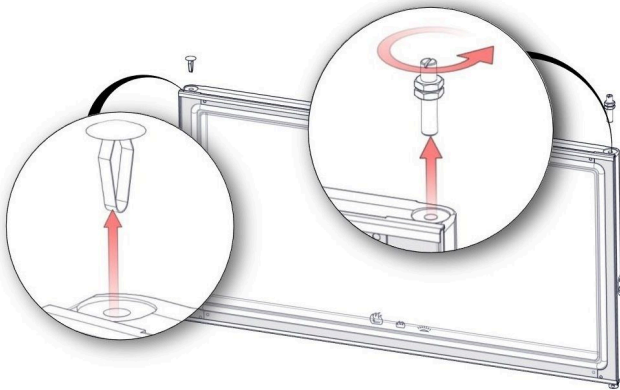

**14:**

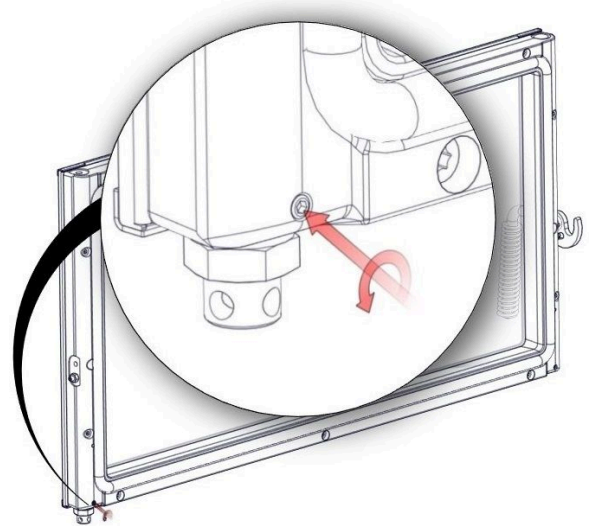

**15:**

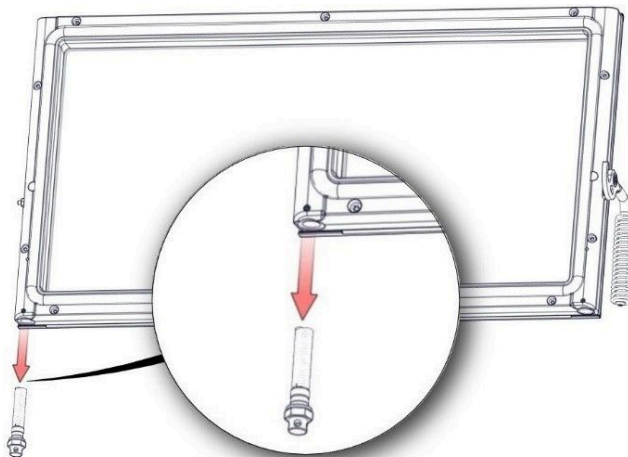

**16:**

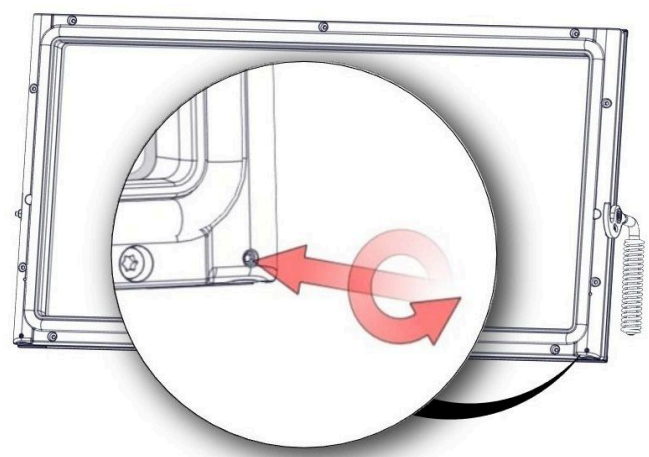



**17:**

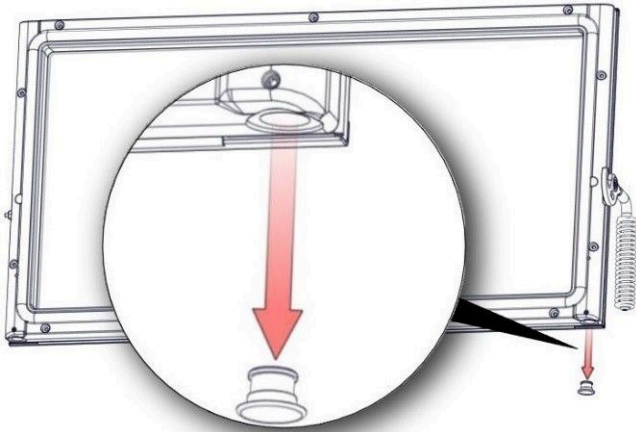

**18:**

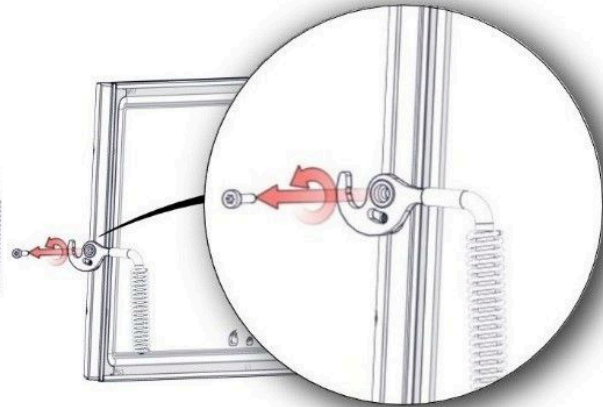

**19:**

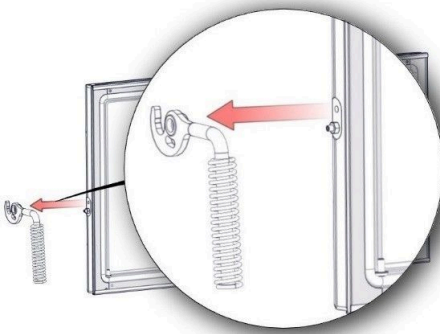

**20:**

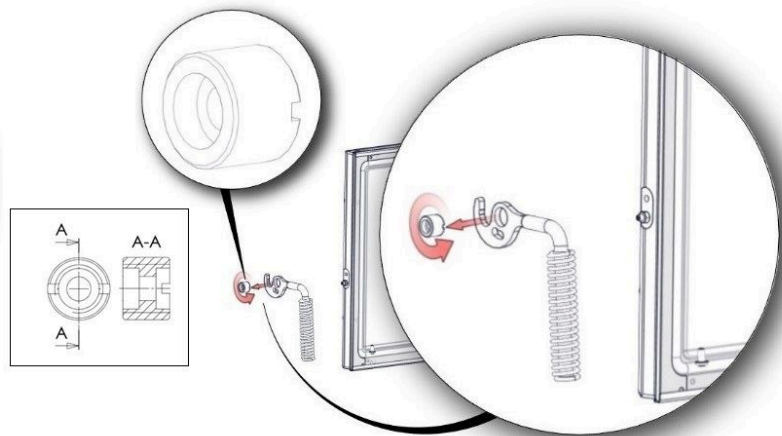

**21:**

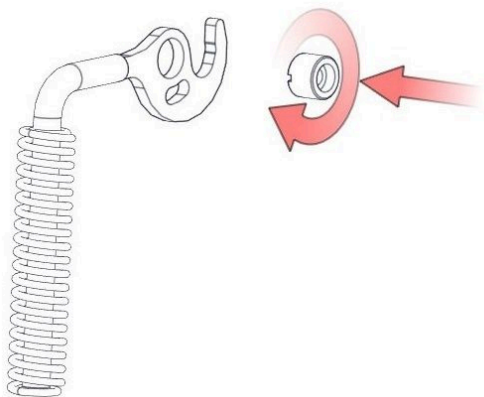

**22:**

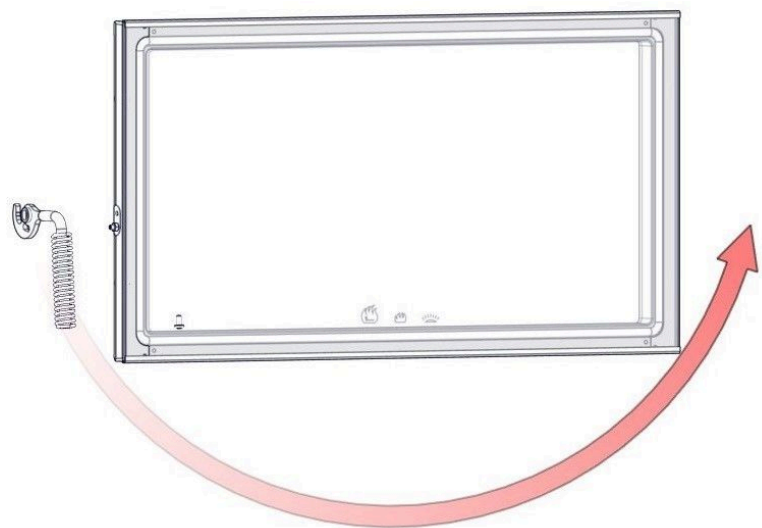

**22 -> 21 -> 20 -> 19 ..... -> 1**

# Dimension sheets - HKD 7

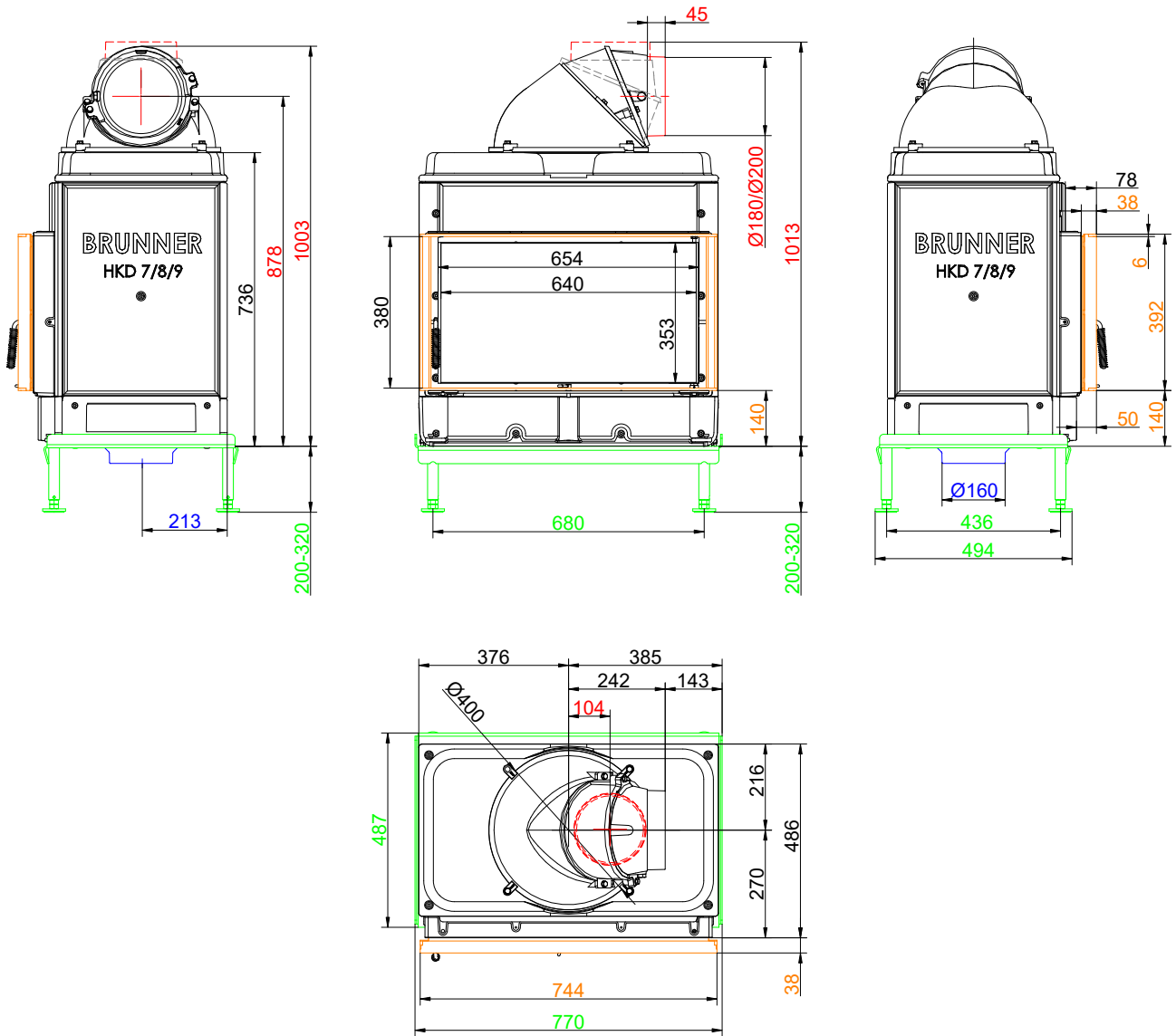

... mounting frame and cast iron dome

# Dimension sheets - HKD 7

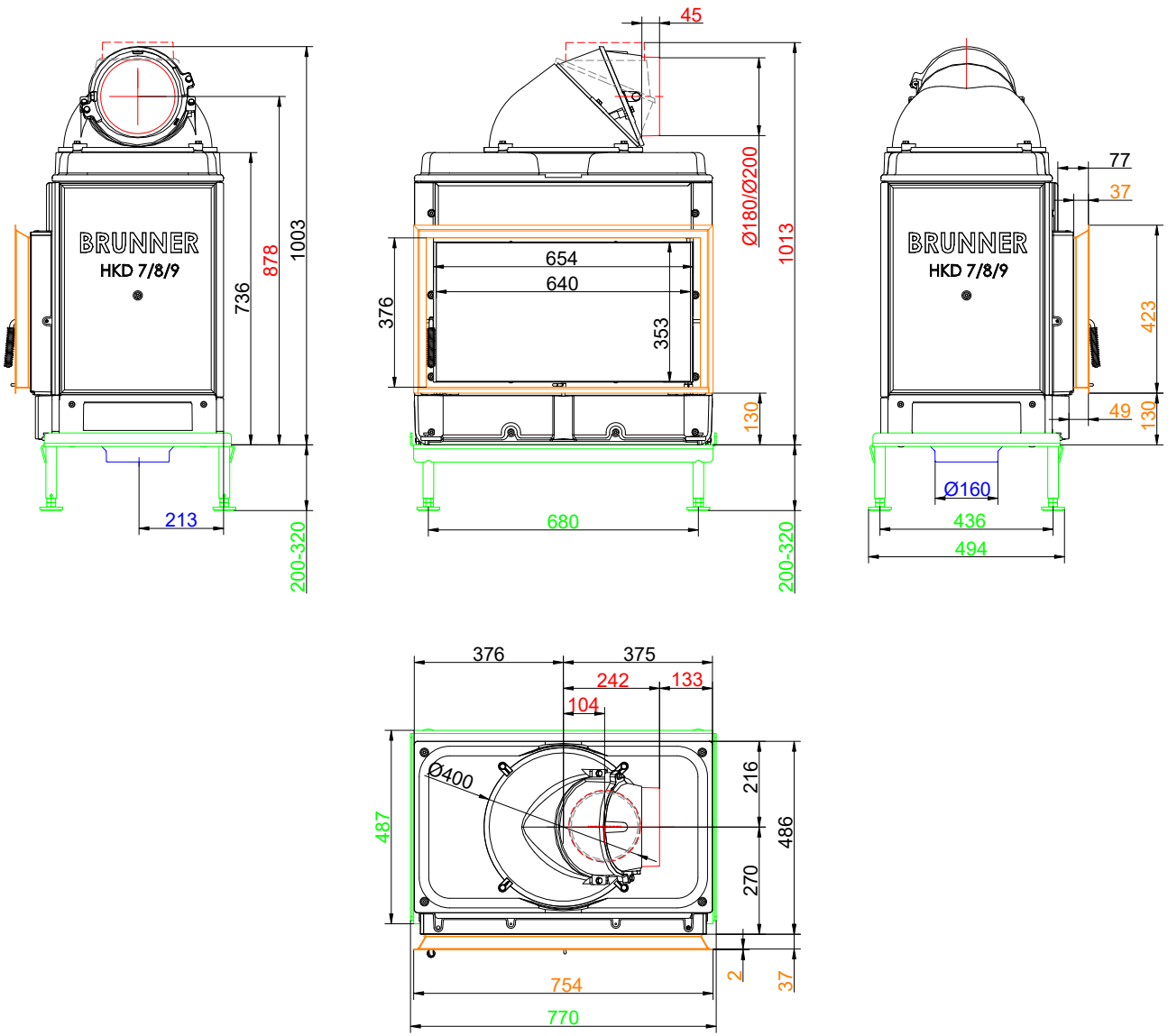

... door frame and cast iron dome

# Dimension sheets - HKD 7

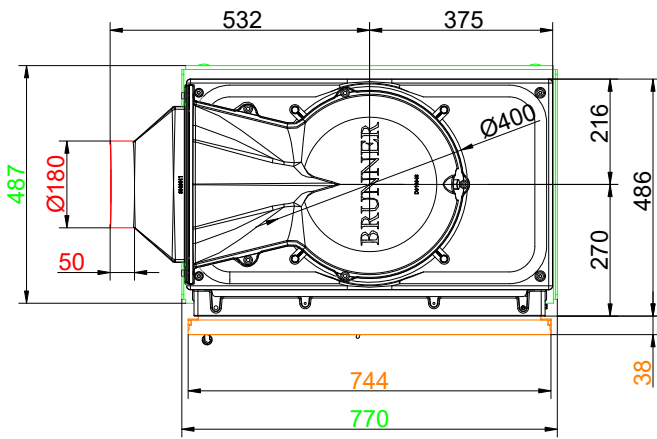
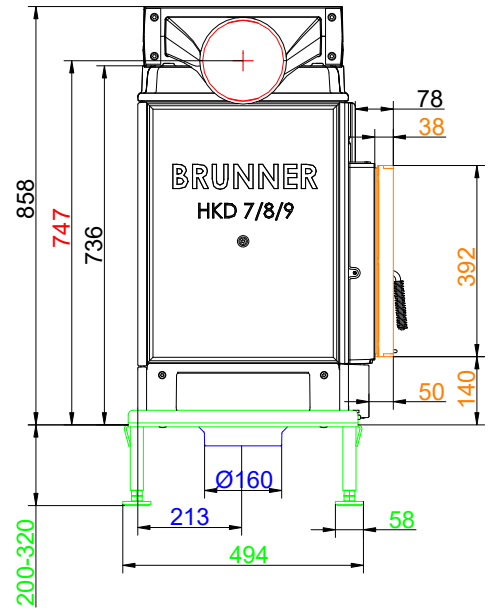
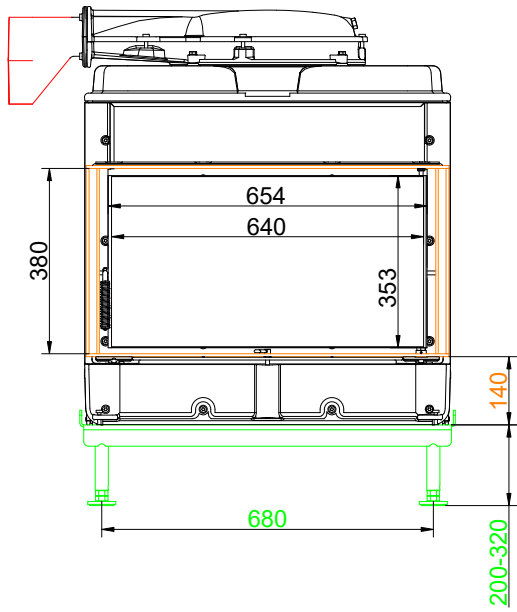

... mounting frame and cast iron dome low

# Dimension sheets - HKD 7

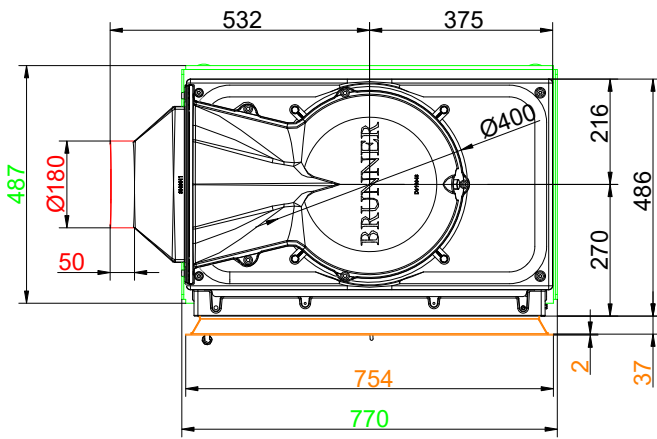
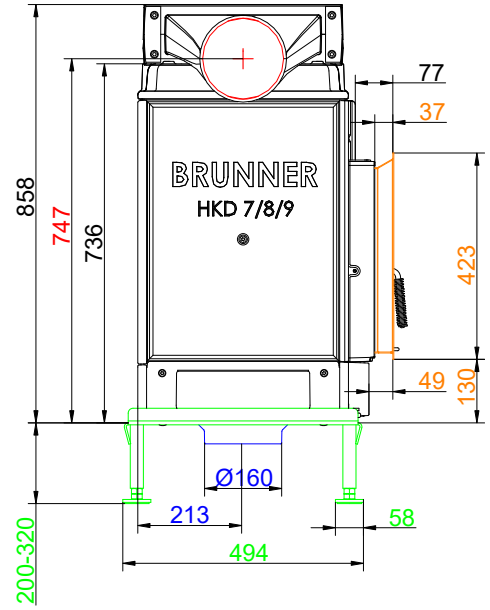
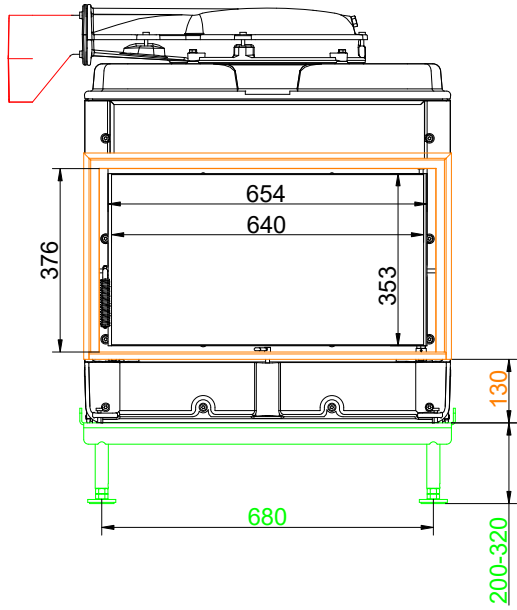

... door frame and cast iron dome low

# Dimension sheets - HKD 7

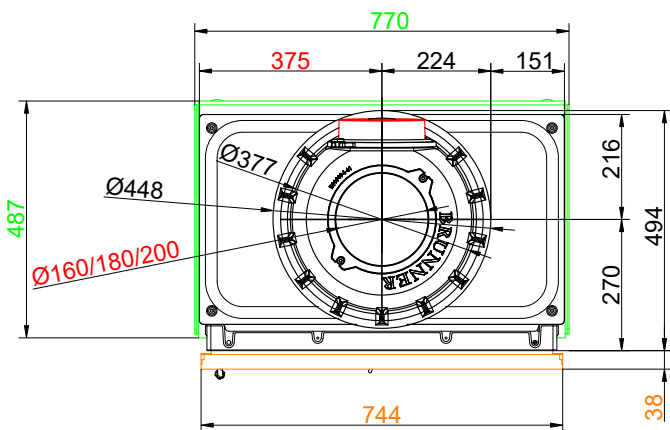
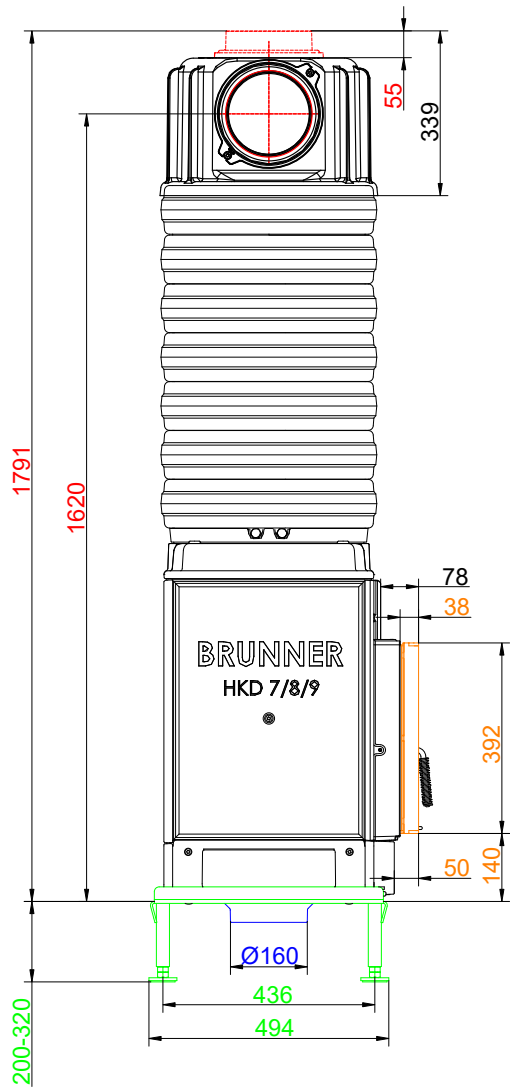
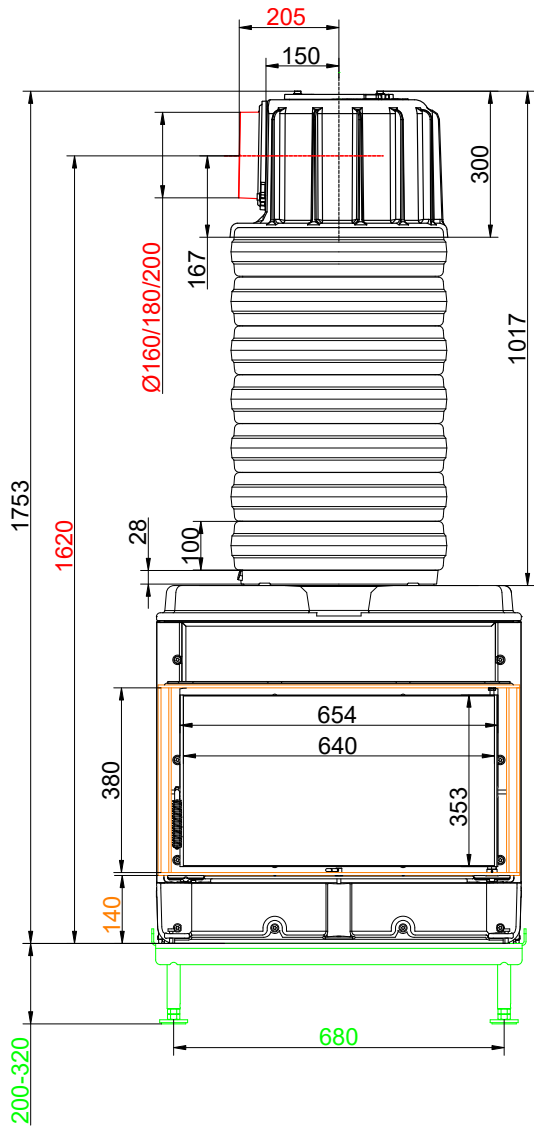

... mounting frame and MAS

# Dimension sheets - HKD 7

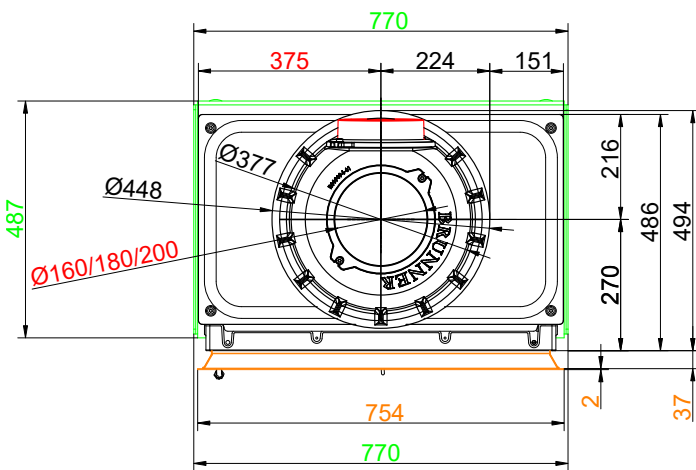
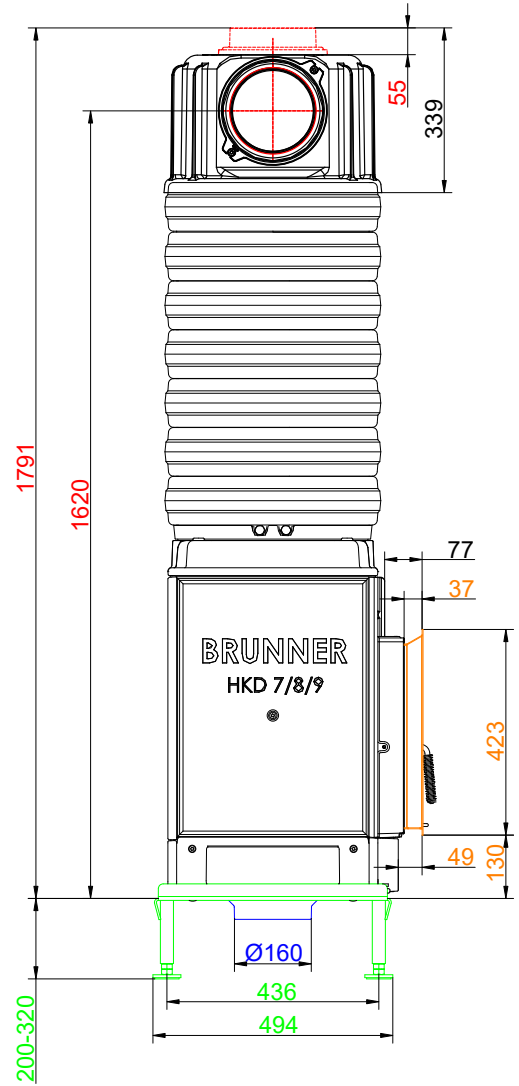
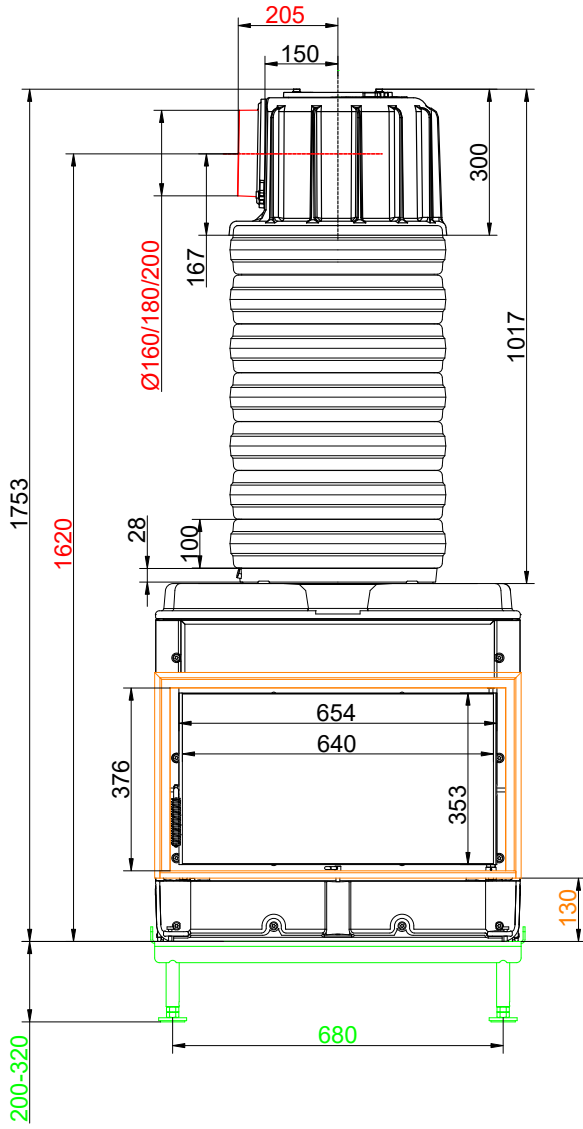

... door frame and MAS



# Dimension sheets - HKD 7

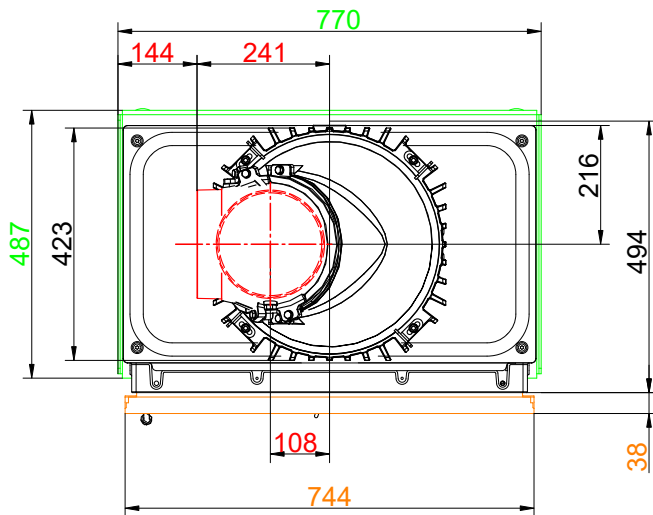
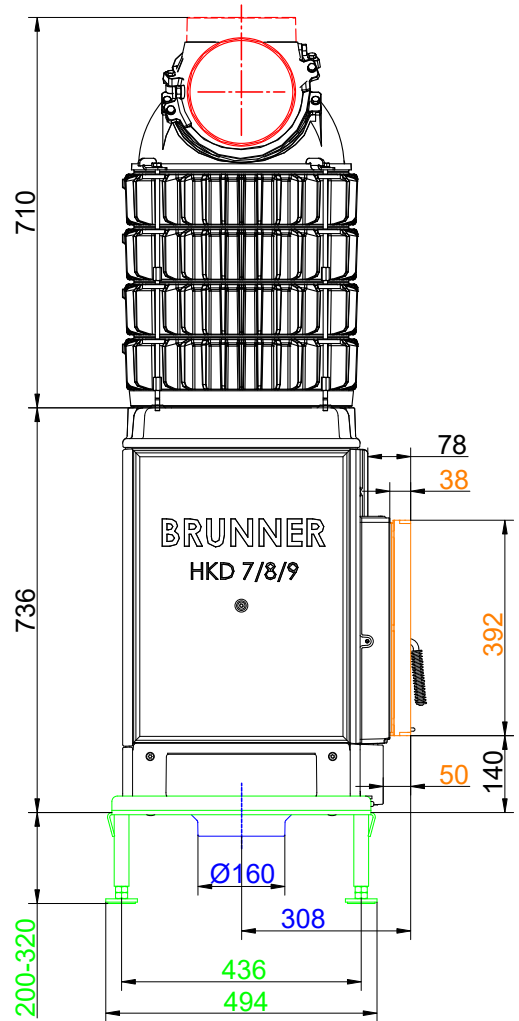
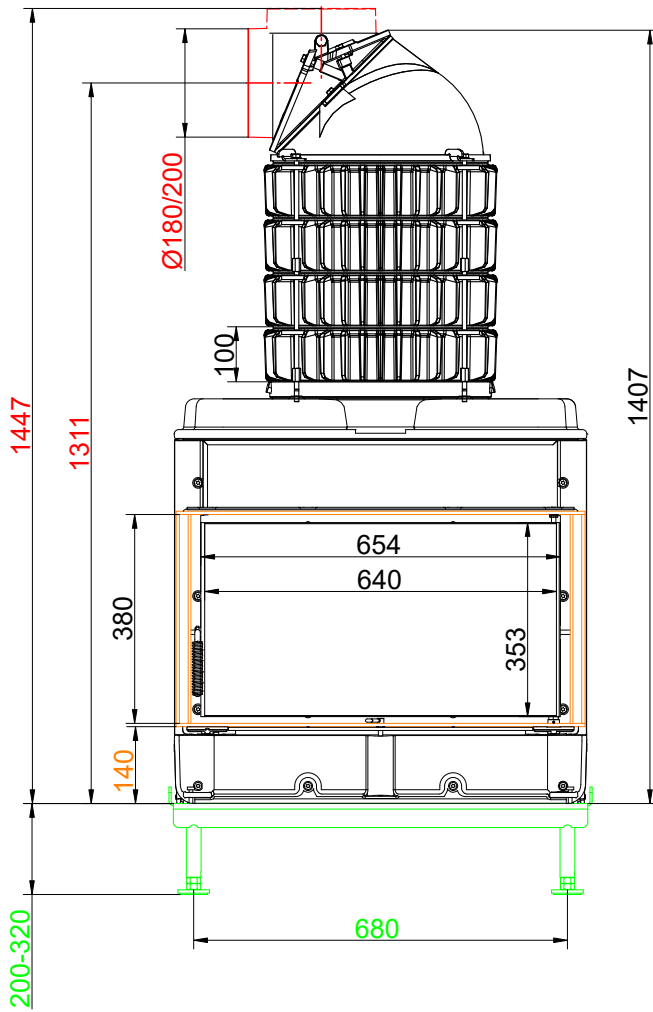

... Mounting frame and cast iron heat exchanger rings + dome

# Dimension sheets - HKD 7

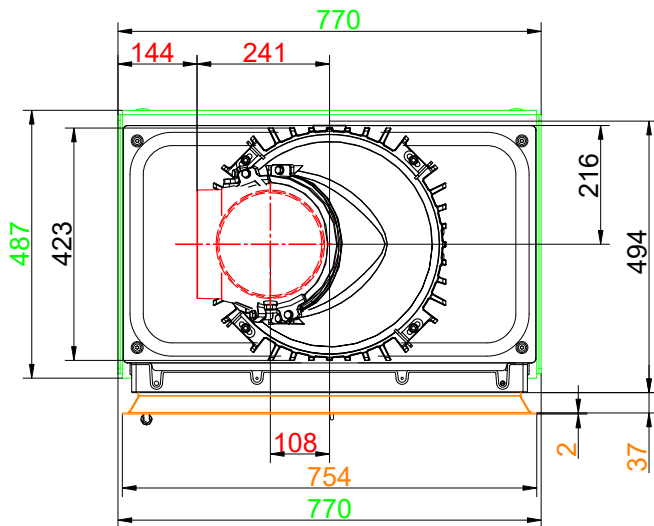
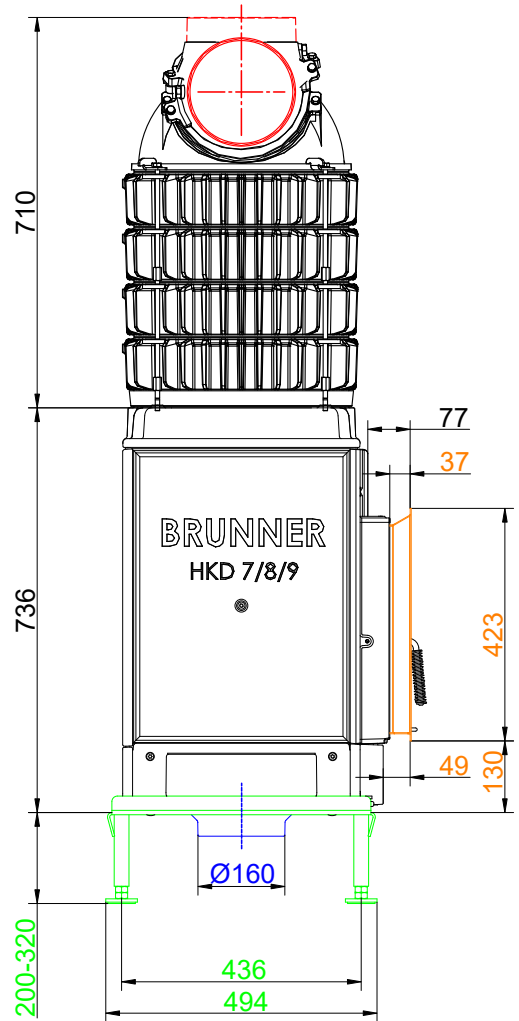
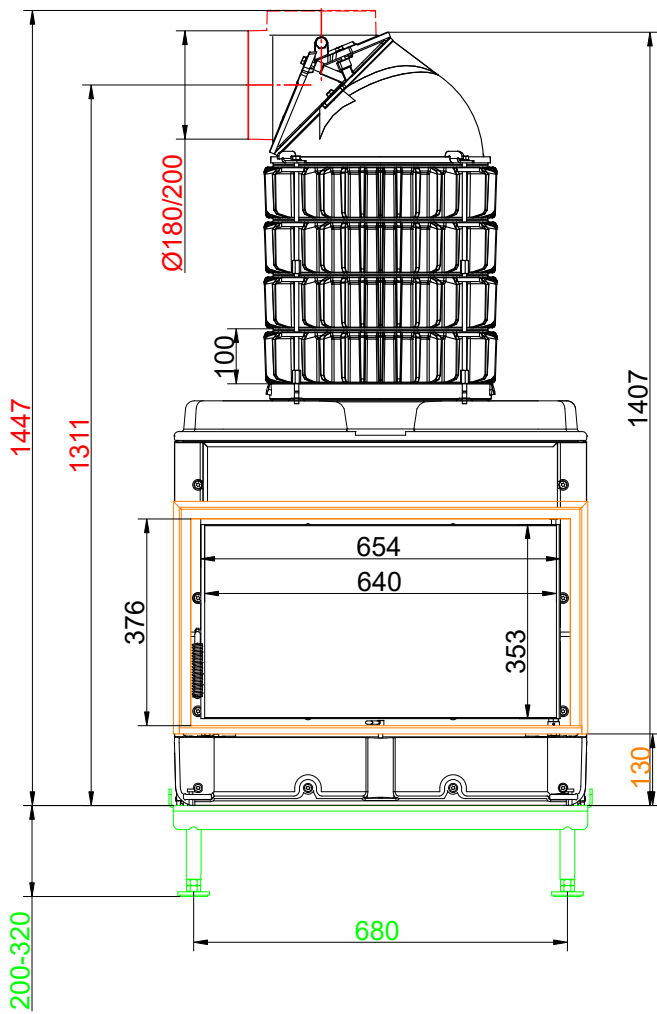

... Door frame and cast iron heat exchanger rings + dome

## Dimension sheets - HKD 7

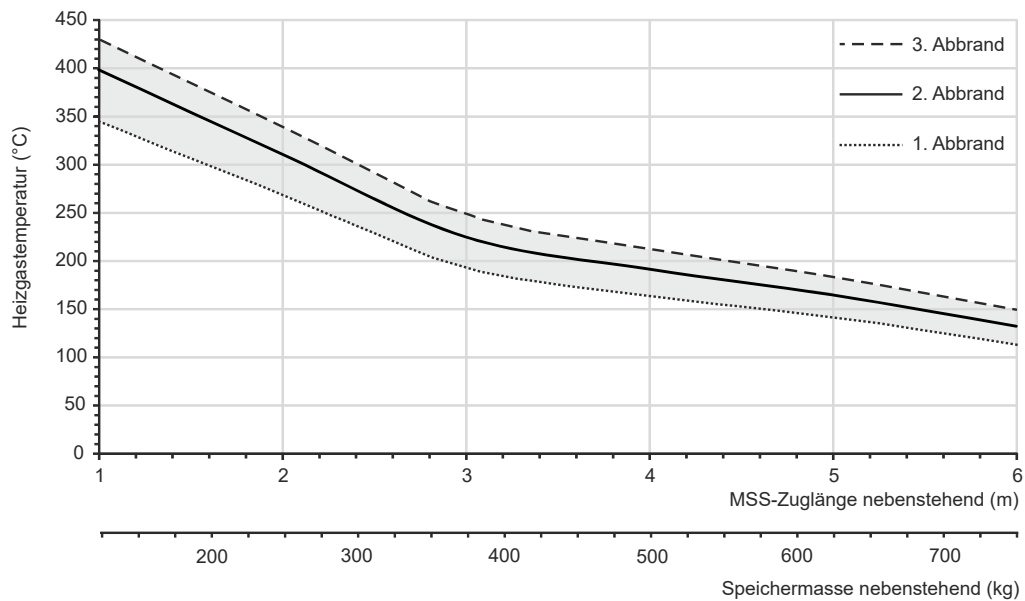

### Design characteristics for adjacent storage mass

We suggest for CAD planning Palette CAD. Permanent updated drawings: [www.brunner.de](http://www.brunner.de)

Frames/ flue gas outlet connection/ combustion air supply connection/ front variants/ support bearing are marked in color.

## Planning and installation - HKD 7

Tested according to		EN 13229 W	EN 13229 WA
Values measured at		Rated power <sup>1)</sup>	Storage operation <sup>2)</sup>
Suitable for all construction types according to rules		OK	OK
<b>Data for functional demonstration</b>			
Rated heat power	kW	9	-
Fire wood volume	kg/h	2.7	5.5
Combustion performance	kW	10.5	22.0
Flue gas mass flow	g/s	8.5	20.0
Outlet temperature (before reheating surface)	°C	460	540
Flue gas temperature after:			
1 x adjoining cast iron radiator (GNF 8/10)	°C	180	215
4 x cast iron heat exchanger rings + dome	°C	220	260
7 x accumulation rings incl. MAS casted cover <sup>3)</sup>	°C	220	-
4,9 m ceramic accumulator <sup>4)</sup>	°C	-	180
3,4 m accumulation stones (MSS) <sup>4)</sup>	°C	-	190
Necessary supply pressure	Pa	12	15
Combustion air consumption	m <sup>3</sup> /h	25	48
Flue gas pipe connection Ø	mm	180 / 200	180 / 200
Combustion air connection Ø	mm	125 / 160	125 / 160
<b>Heating gas temperature (before the hood/dome variant)</b>			
cast iron dome	°C	460	540
<b>Heat distribution</b>			
Insert / reheating surface	%	40 / 40	40 / 40
Glass pane (single / double)	%	- / 20	- / 20
<b>Cross-section of gratings <sup>5)</sup></b>			
exhaust warm air	cm <sup>2</sup>	700 / 300 / 500	700 / 300 / 500
Recirculation air	cm <sup>2</sup>	700 / 300 / 500	700 / 300 / 500
<b>Minimal distances of the fireplace</b>			
to cladding, insulation layer	cm	8	8
to mounting floor	cm	15	15
<b>Thermal insulation without / with air gratings <sup>6)</sup></b>			
Mounting wall	cm	12 / 10	12 / 10
Floor	cm	0	0
Ceiling	cm	22 / 16	22 / 16
Brick lining for combustible wall	cm	10	10
<b>Weight</b>			
Fireplace / combustion chamber	kg	248 / 66	
<b>Meets requirement/limit values for:</b>			
Germany/ Austria / Switzerland / Norway		1.BImSchV (Stufe 2) / 15a BvG (2015) / LRV / -	

- 1) Indications to "Rated power" determined with metallic reheating surface
- 2) Indications to "Storage operation" for the manual execution of the reheating surface (guide values).
- 3) Damper flap recommended
- 4) Approximate value. Determination according to design characteristics for adjacent storage mass or proof of function provided by calculation
- 5) for fireplace/heating inserts / flue gas pipe / metallic reheating surface/if the specified nominal heat output is required as the heating output.
- 6) Brandsicherheit: Werte ermittelt in Sicherheitsprüfung mit prüftechnisch erfassten Luftquerschnitten; Ofenhülle wärmeabgebend ausgeführt. Dämmstoffangaben mit Referenzdämmstoff (Mineralwolle nach AGI Q 132).

# Dimension sheets - HKD 7 Tunnel

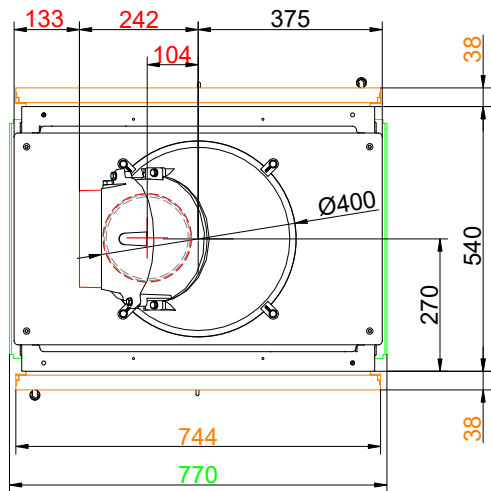
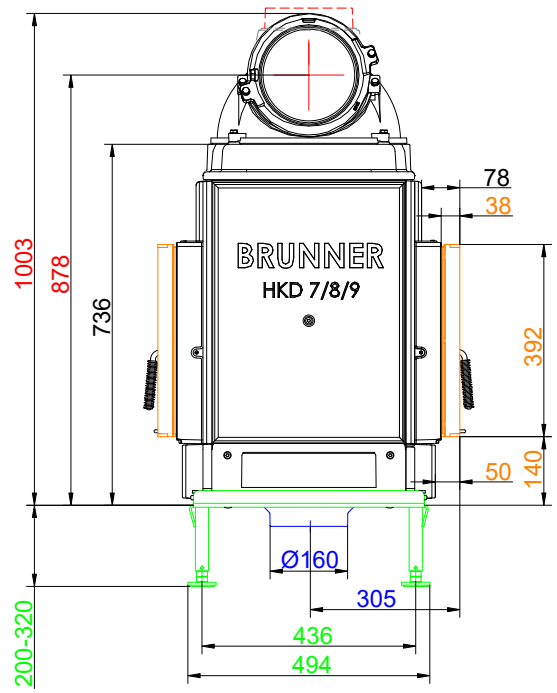
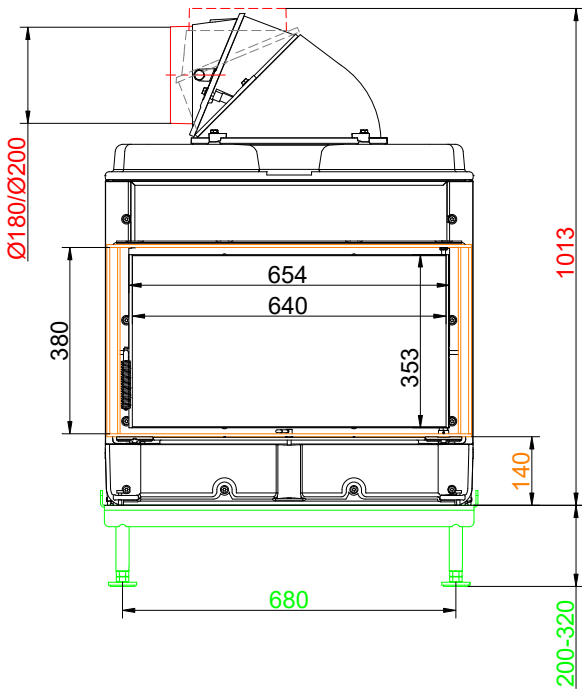

... mounting frame and cast iron dome

# Dimension sheets - HKD 7 Tunnel

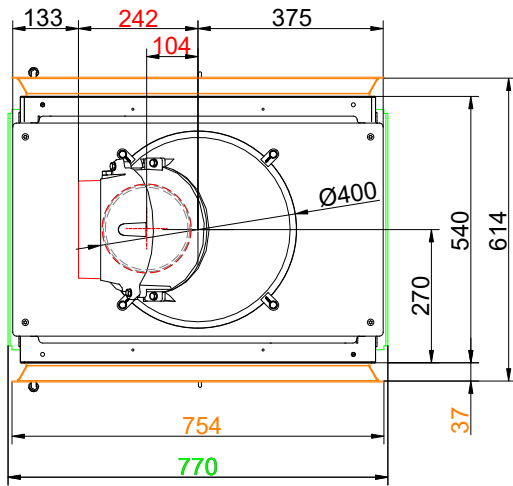
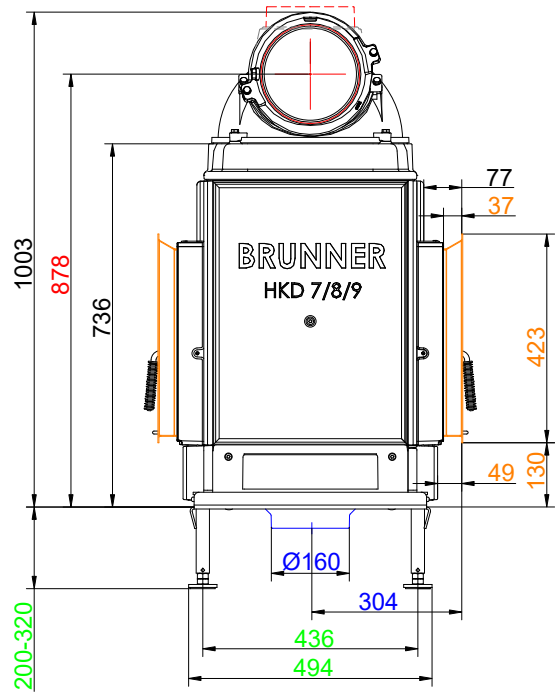
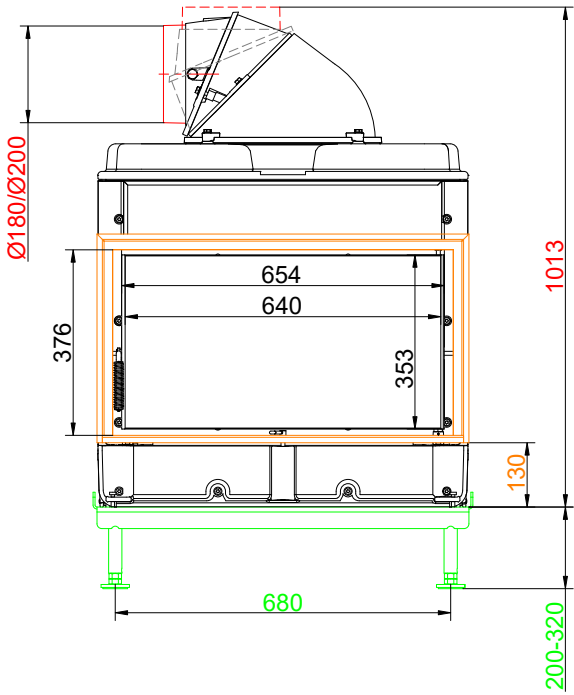

... door frame and cast iron dome

# Dimension sheets - HKD 7 Tunnel

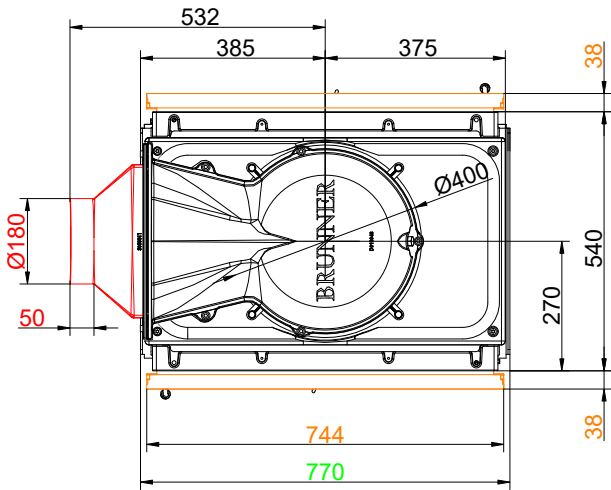
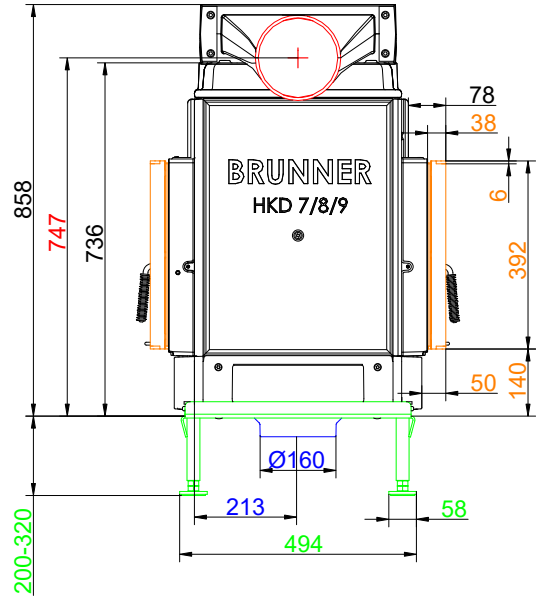
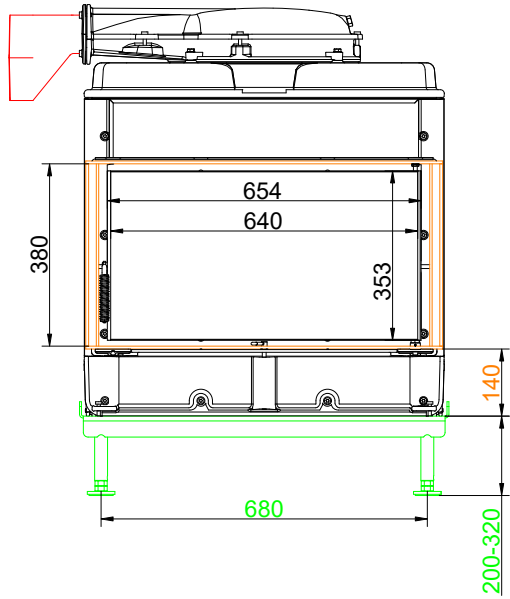

... mounting frame and cast iron dome low

# Dimension sheets - HKD 7 Tunnel

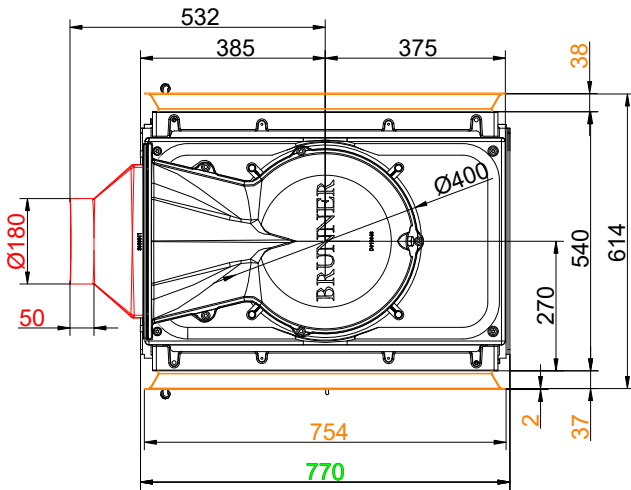
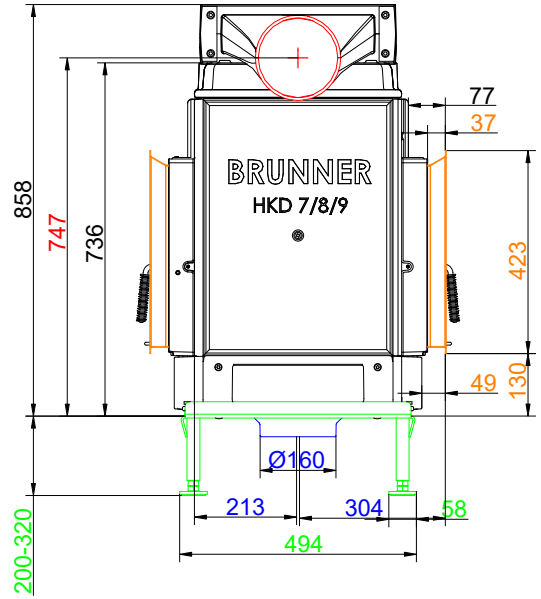
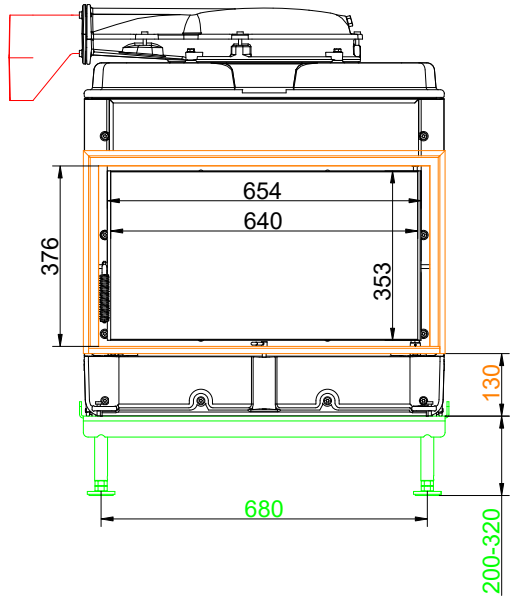

... door frame and cast iron dome low



# Dimension sheets - HKD 7 Tunnel

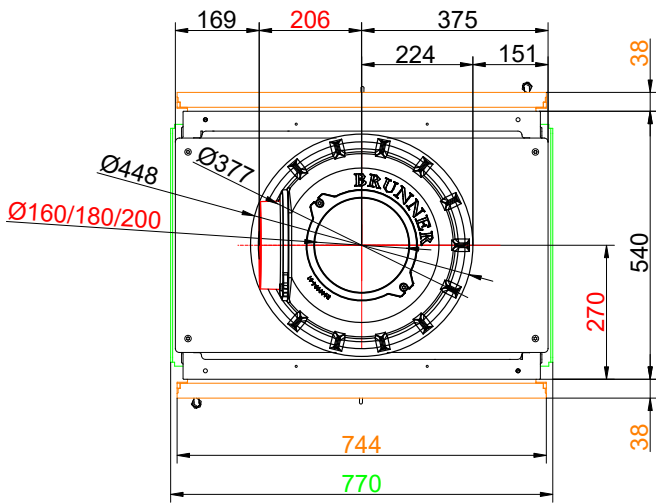
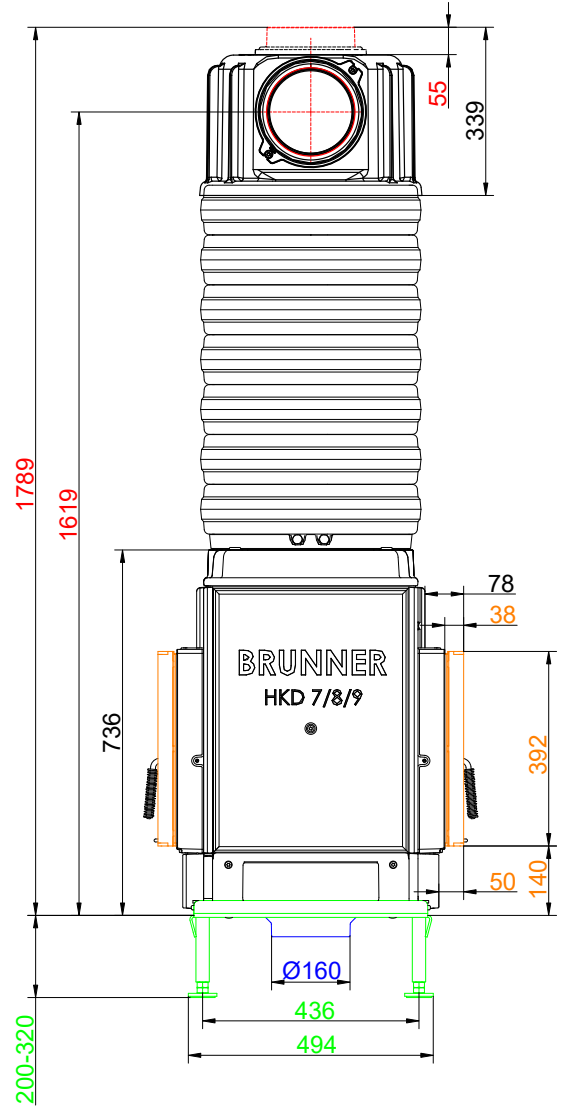
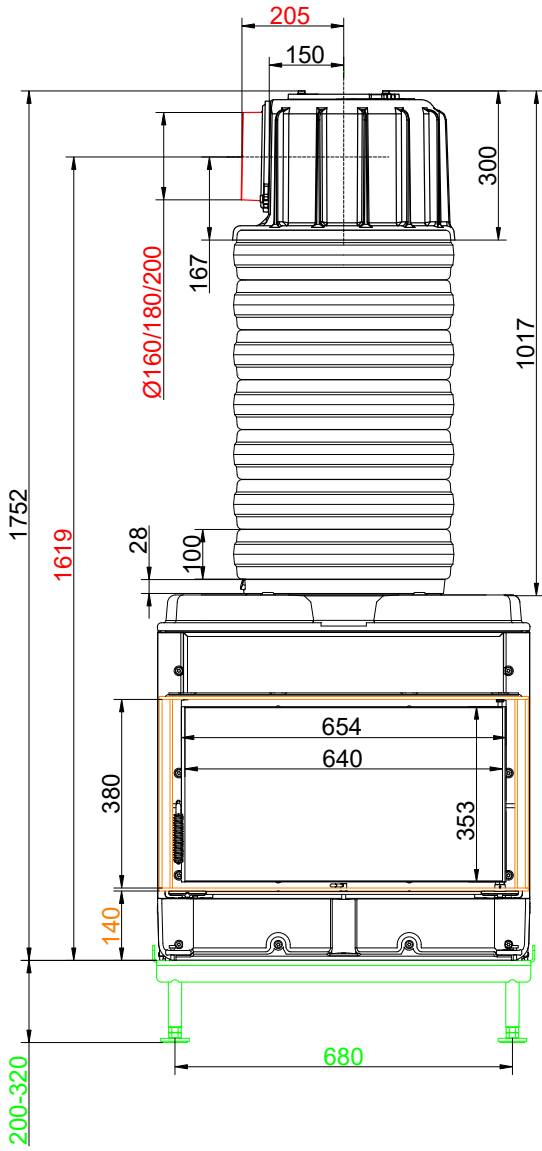

... mounting frame and MAS

# Dimension sheets - HKD 7 Tunnel

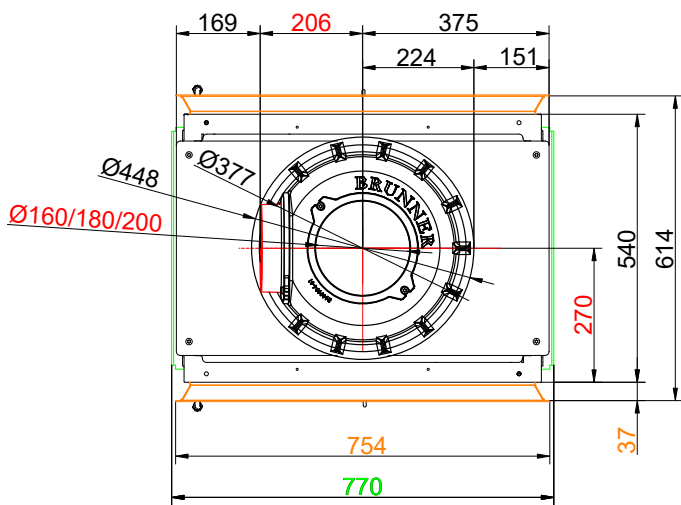
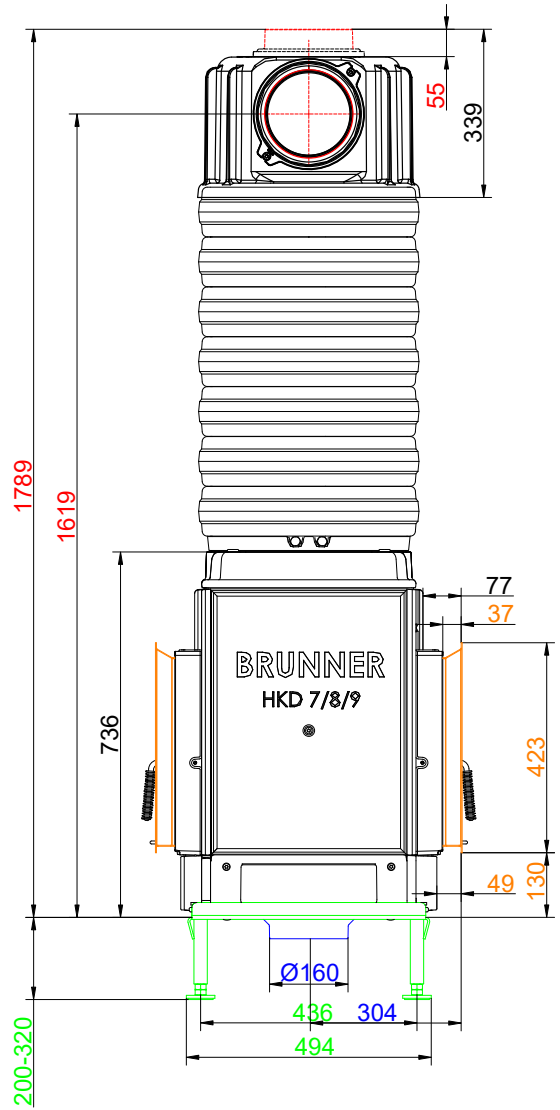
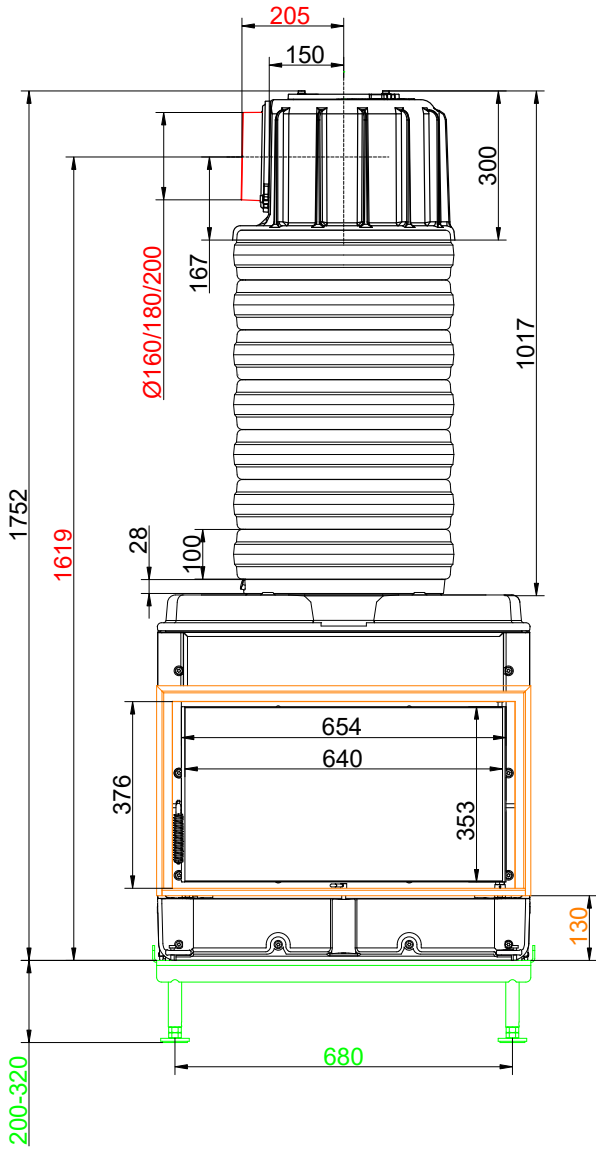

... door frame and MAS

# Dimension sheets - HKD 7 Tunnel

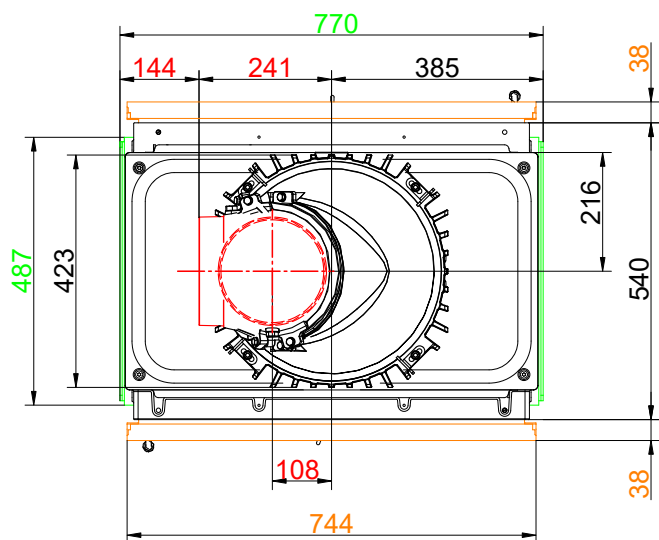
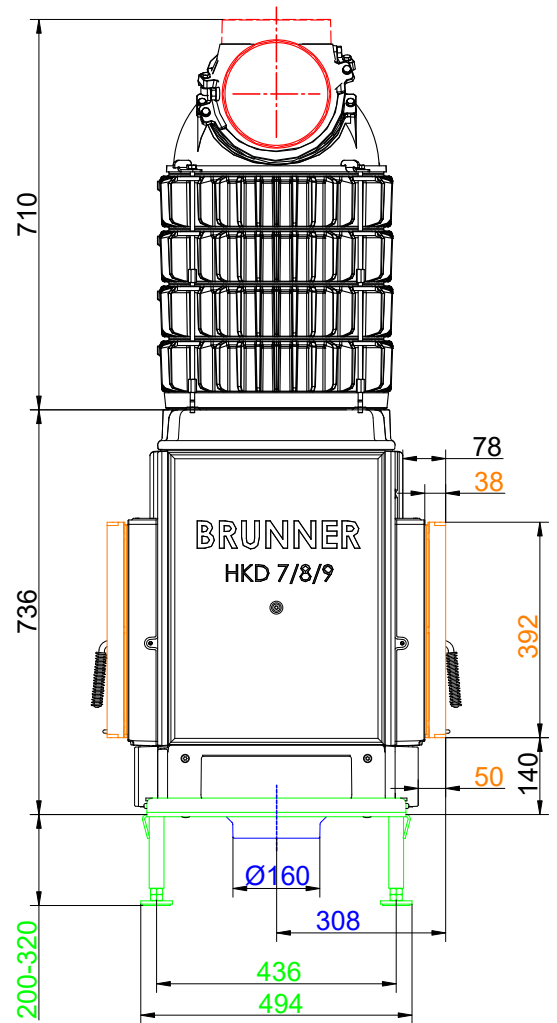
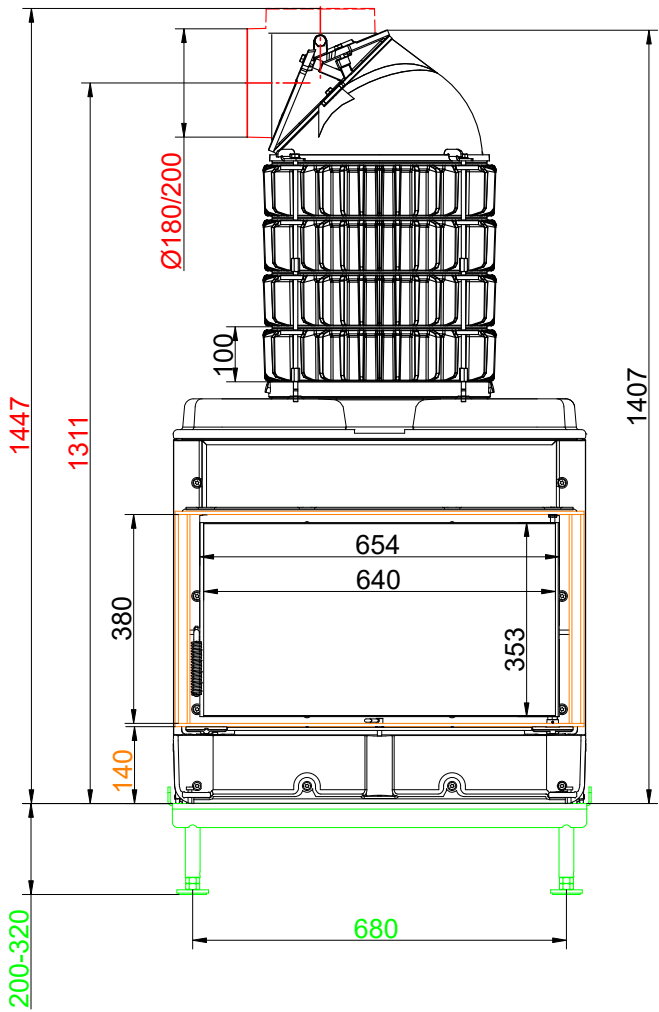

... Mounting frame and cast iron heat exchanger rings + dome

# Dimension sheets - HKD 7 Tunnel

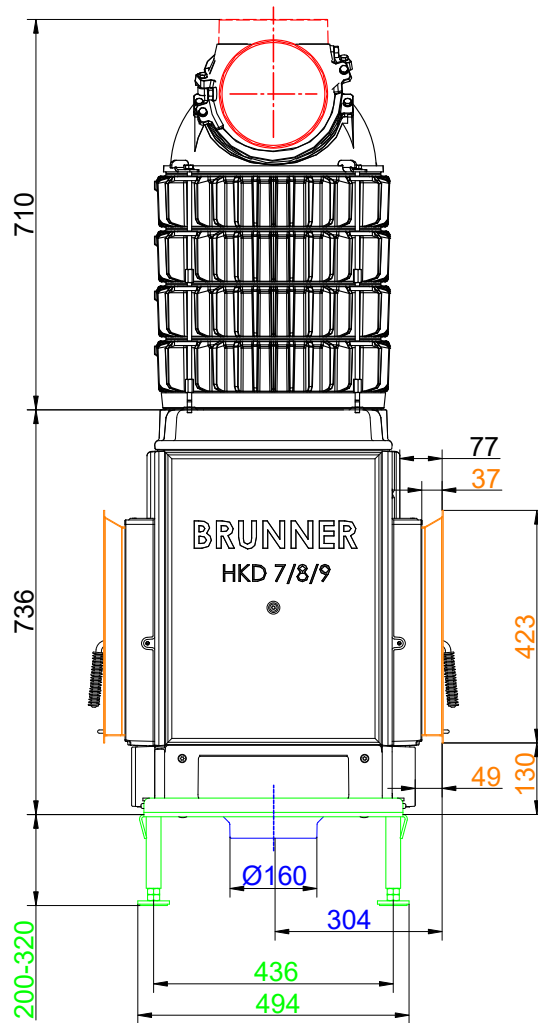
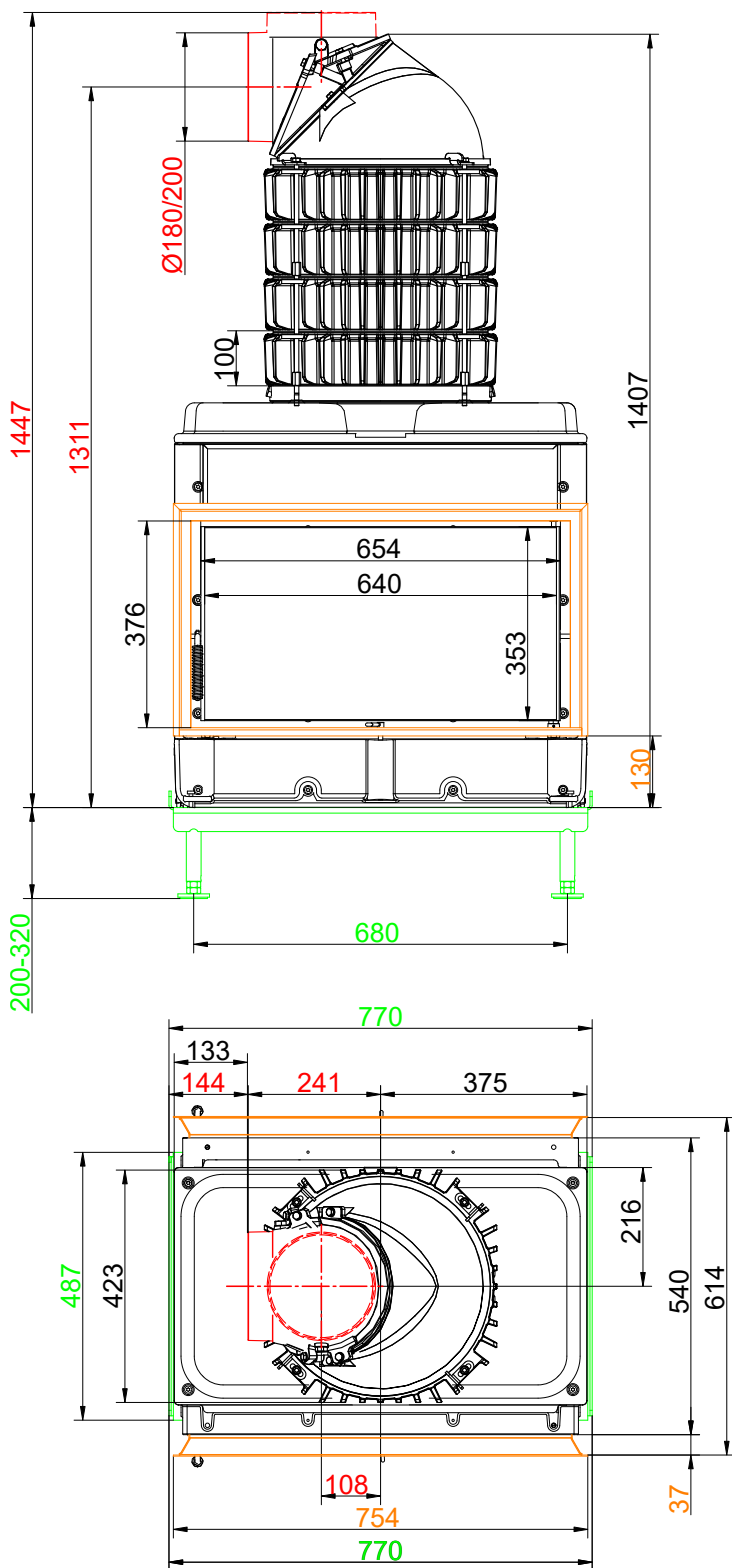

... Door frame and cast iron heat exchanger rings + dome

## Dimension sheets - HKD 7 Tunnel

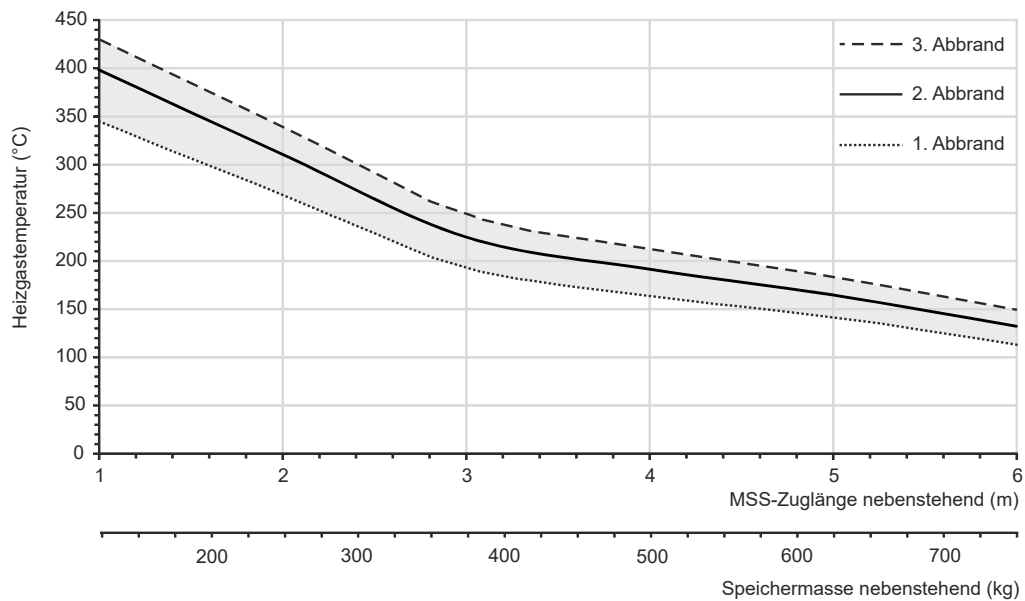

### Design characteristics for adjacent storage mass

We suggest for CAD planning Palette CAD. Permanent updated drawings: [www.brunner.de](http://www.brunner.de)

Frames/ flue gas outlet connection/ combustion air supply connection/ front variants/ support bearing are marked in color.

# Planning and installation - HKD 7 Tunnel

Tested according to		EN 13229 W	EN 13229 WA
Values measured at		Rated power <sup>1)</sup>	Storage operation <sup>2)</sup>
Suitable for all construction types according to rules		OK	OK
<b>Data for functional demonstration</b>			
Rated heat power	kW	9	-
Fire wood volume	kg/h	2.7	5.5
Combustion performance	kW	10.5	22.0
Flue gas mass flow	g/s	8.5	20.0
Outlet temperature (before reheating surface)	°C	460	540
Flue gas temperature after:			
1 x adjoining cast iron radiator (GNF 8/10)	°C	180	215
7 x accumulation rings incl. MAS casted cover <sup>3)</sup>	°C	220	-
4,9 m ceramic accumulator <sup>4)</sup>	°C	-	180
3,4 m accumulation stones (MSS) <sup>4)</sup>	°C	-	190
Necessary supply pressure	Pa	12	15
Combustion air consumption	m <sup>3</sup> /h	25	48
Combustion air connection Ø	mm	125 / 160	125 / 160
<b>Heating gas temperature (before the hood/dome variant)</b>			
cast iron dome	°C	460	540
<b>Heat distribution</b>			
Insert / reheating surface	%	30 / 40	30 / 40
Glass pane (single / double)	%	- / 30	- / 30
<b>Cross-section of gratings <sup>5)</sup></b>			
exhaust warm air	cm <sup>2</sup>	700 / 300 / 500	700 / 300 / 500
Recirculation air	cm <sup>2</sup>	700 / 300 / 500	700 / 300 / 500
<b>Minimal distances of the fireplace</b>			
to cladding, insulation layer	cm	8	8
to mounting floor	cm	15	15
<b>Thermal insulation without / with air gratings <sup>6)</sup></b>			
Mounting wall	cm	12 / 10	12 / 10
Floor	cm	0	0
Ceiling	cm	22 / 16	22 / 16
Brick lining for combustible wall	cm	10	10
<b>Weight</b>			
Fireplace / combustion chamber	kg	291 / 46	
<b>Meets requirement/limit values for:</b>			
Germany/ Austria / Switzerland / Norway		1.BImSchV (Stufe 2) / 15a BVG (2015) / LRV / -	

- 1) Indications to "Rated power" determined with metallic reheating surface
- 2) Indications to "Storage operation" for the manual execution of the reheating surface (guide values).
- 3) Damper flap recommended
- 4) Approximate value. Determination according to design characteristics for adjacent storage mass or proof of function provided by calculation
- 5) for fireplace inserts / flue gas pipe / metallic reheating surface
- 6) Brandsicherheit: Werte ermittelt in Sicherheitsprüfung mit prüftechnisch erfassten Luftquerschnitten; Ofenhülle wärmeabgebend ausgeführt. Dämmstoffangaben mit Referenzdämmstoff (Mineralwolle nach AGI Q 132).

**Product data sheet according to (EU) 2015/1186:**

Supplier's name or trademark	Ulrich Brunner GmbH
Model identifier:	HKD 7
Energy efficiency class:	A+
Direct heat output:	9,0 kW
Indirect heat output:	N.A. kW
Energy efficiency index:	109
Fuel energy efficiency (at nominal heat output):	82,0 %
Fuel energy efficiency (at minimum load):	N.A. %
Special precautions: see supplied product documentation	

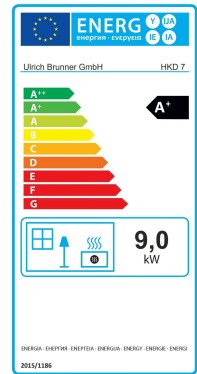

**Product data sheet according to (EU) 2015/1186:**

Supplier's name or trademark	Ulrich Brunner GmbH
Model identifier:	HKD 7 Tunnel
Energy efficiency class:	A+
Direct heat output:	9,0 kW
Indirect heat output:	N.A. kW
Energy efficiency index:	109
Fuel energy efficiency (at nominal heat output):	82,0 %
Fuel energy efficiency (at minimum load):	N.A. %
Special precautions: see supplied product documentation	

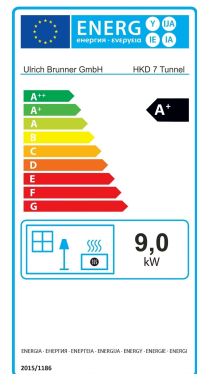

Ulrich Brunner GmbH  
 Zellhuber Ring 17-18  
 D-84307 Eggenfelden  
 Tel.: +49 (0) 8721/771-0 / Fax: +49 (0) 8721/771-100  
 Email: info@brunner.de

Technical and assortment changes as well as errors and misprints reserved.  
 Reprinting and reproduction, even in part, only with the express permission of the publisher.

**Art.Nr.: 200254**